

# Expandable Well Technology



**David Butler**

**david.butler@eu.weatherford.com**

**Weatherford – Aberdeen U.K.**

- **Slotted / Perforated Expandable Tubular Technology**
  - **Solid Tubular Expandable Technology**
    - **Technology Development History**
    - **Expansion Methodology**
    - **Applications**
    - **Case Histories**
    - **What the future holds for this technology??**
-

# Unique Expandable Products for each Technology Market Sector

## Market Sectors

### Completions

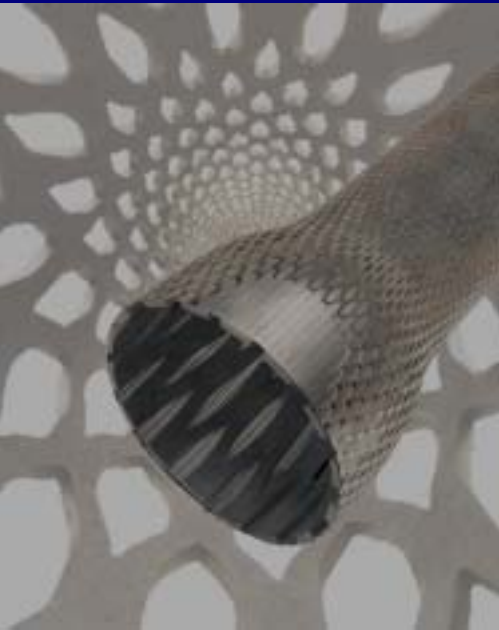

Expandable Sand Screen

### Wellbore Enhancement



Cased Hole Liners  
& Cladding



Openhole Liners



Alternative  
Borehole Liner

## Expandable Products

## ● Technology Development History

- ⑩ Shell Research initiates expandable studies late 1980's
  - ⑩ Shell develops Expandable Sand Control Screen Concept 1992
  - ⑩ R & D agreement signed with Petroline for Slotted Expandables February 1993
  - ⑩ Slotted Technology Patent applications 1994
  - ⑩ First Commercial Application Slotted Tubulars 1995 West Texas
  - ⑩ License agreement between Shell & Petroline for Slotted Expandables April 96
  - ⑩ R & D agreement signed with Baker Oil Tools 1997
  - ⑩ Enventure Global Technology created between Halliburton & Shell December 1998
  - ⑩ E<sup>2</sup>Tech created between Baker & Shell February 1999
  - ⑩ First Commercial Solid Expandable installation Chevron Louisiana November 1999
  - ⑩ Shell Research license Weatherford for Solid Expandable April 2002
-

- **Drilling Applications**
- **Completion Application**

# Slotted Tubular Expansion 8 5/8" ABL



# Drilling-Wellbore Size Preservation

## Premature Casing Shoe Depth-Alternative Bore Hole Liner

**Drill through  
and Under-ream  
the problem  
zone. Run  
Caliper log**



**Run in hole  
ABL and sit  
on bottom**



**Expand  
ABL all the way  
to bottom**



**Spot balanced cement  
plug Pull Running Tool  
to top of ABL. Circulate  
out  
excess of cement.  
POOH**

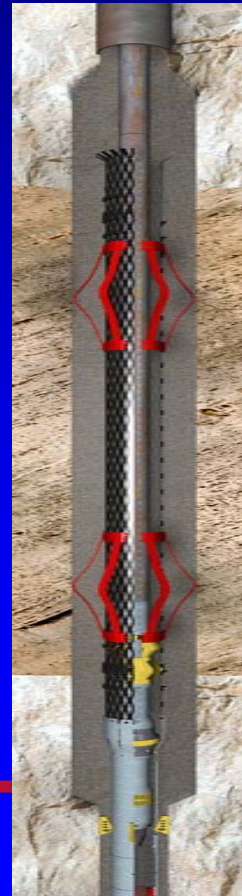

**Wait on cement.  
Drill out cement  
ABL shoe and  
drill ahead**



# Casing/ ABL Interface Options

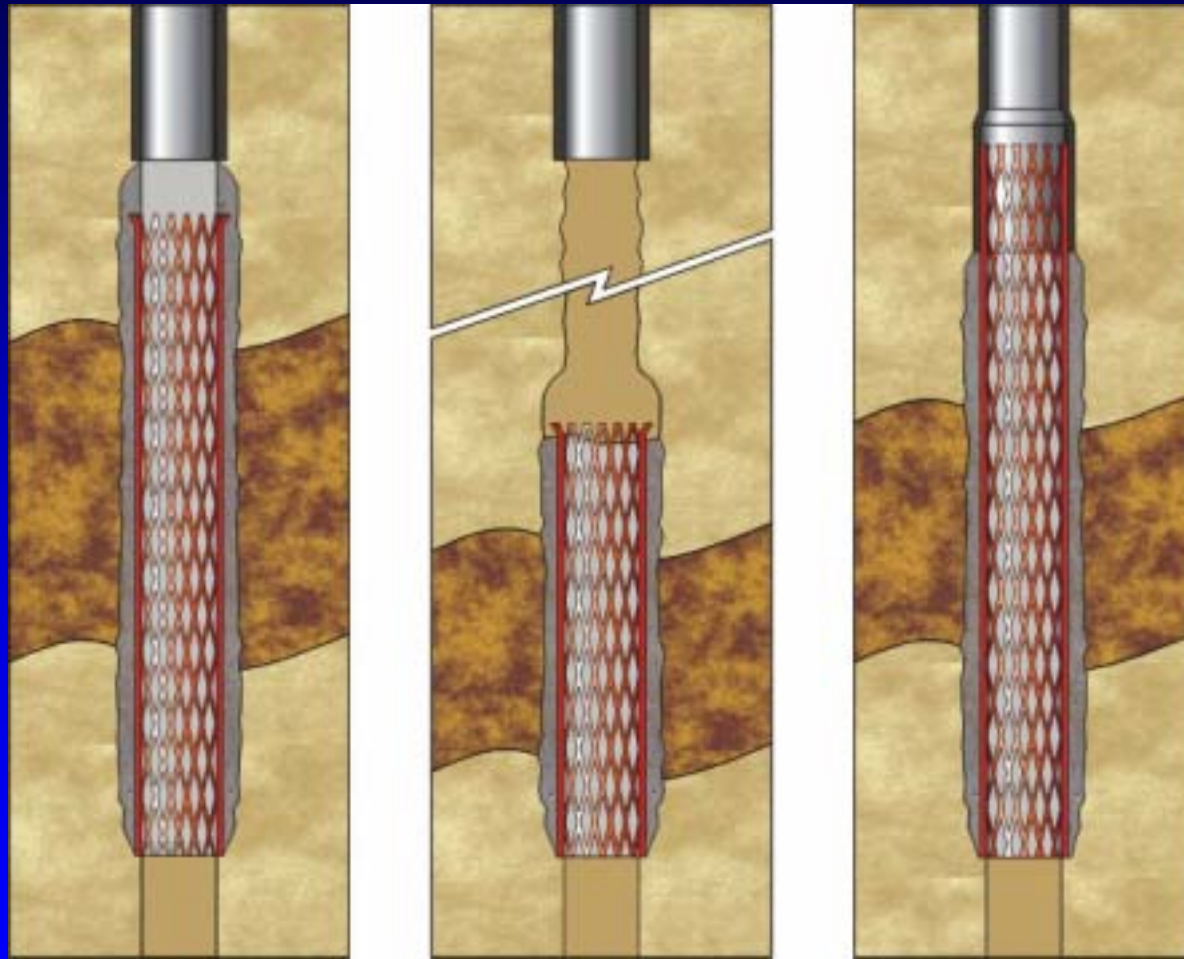

**Open Hole**

**Open Hole with  
Gap**

**Monobore  
Tie-back**

# Expandable Slotted Tubular Drilling Applications

- **Total No of ABL Wells**                    **37**
- **Total Footage Installed**                    **7,212**

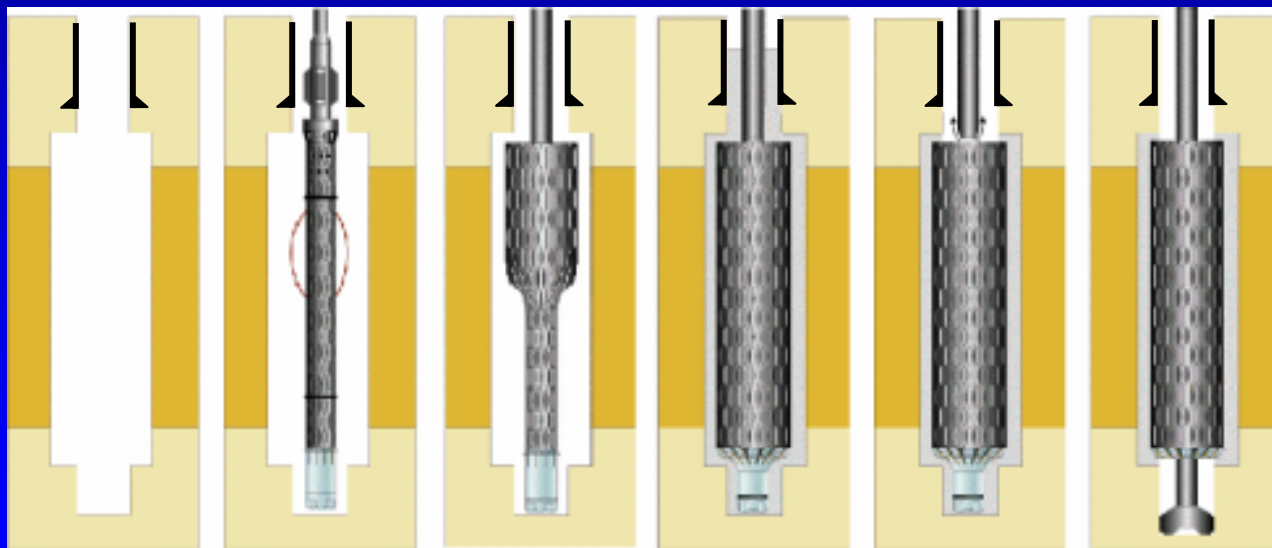

# Slotted Tubular Expansion Fixed Cone Sand Screen



# Small Rotary Expanders



# Expandable Well Technology

## Slotted Expandables - Axial Compliant Expanders



For:

- Reduced expansion force. 8000lbs.
- Extremely efficient expansion.
- Compliant linearly. Conforms to parent bore.
- Extremely wear resistant with standard materials
- No DM required - no rotation.
- No torque induced into ESS.
- Field friendly



**Slotted Tubular Expansion - Compliant**

# Expandable Well Technology

## Axial Compliant Expander

Variable bore test: Bore varied from 5.4" to 6.125".

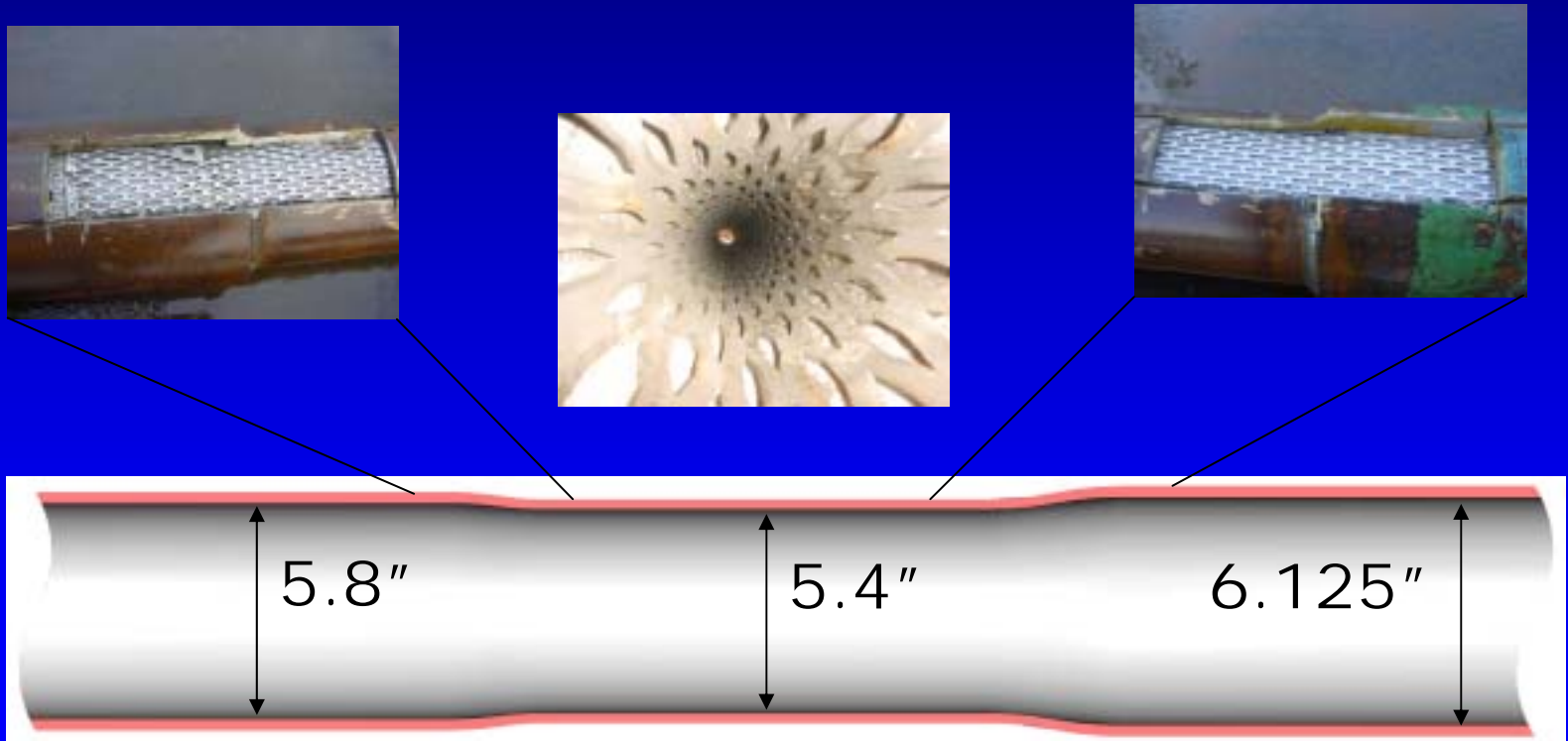

**Slotted Tubular Expansion - Compliant**

# External Gravel Pack V Expandable

(Well Length = 2,200 ft)  
Longer wells are even worse! 6" Openhole

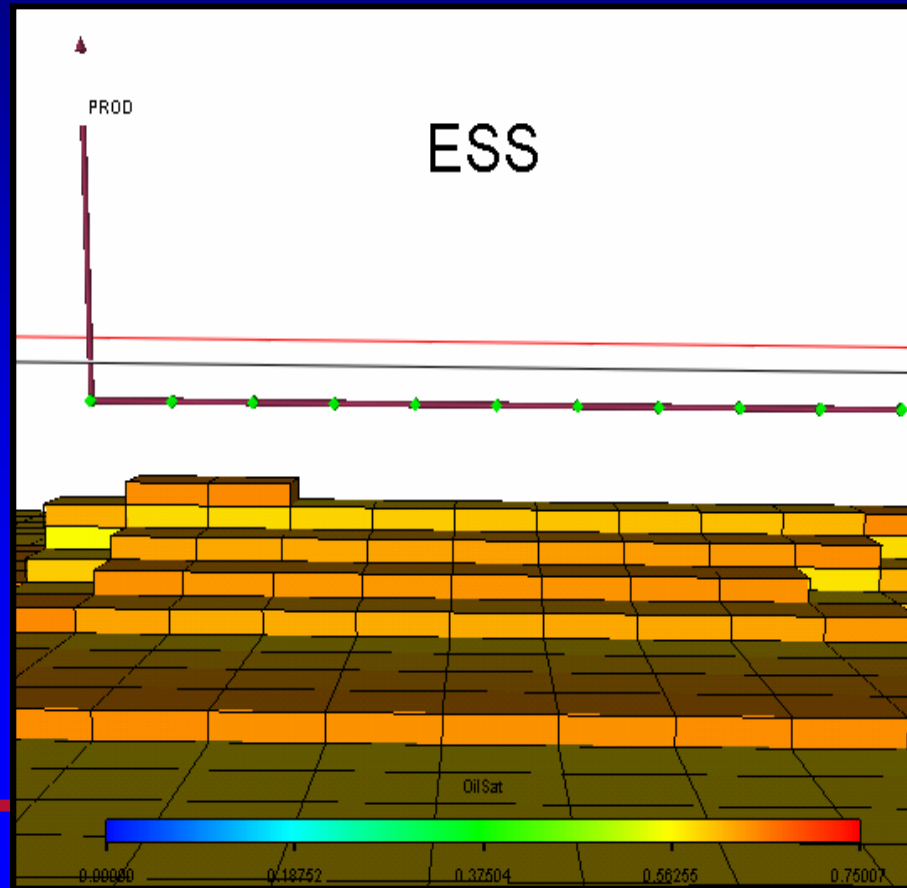
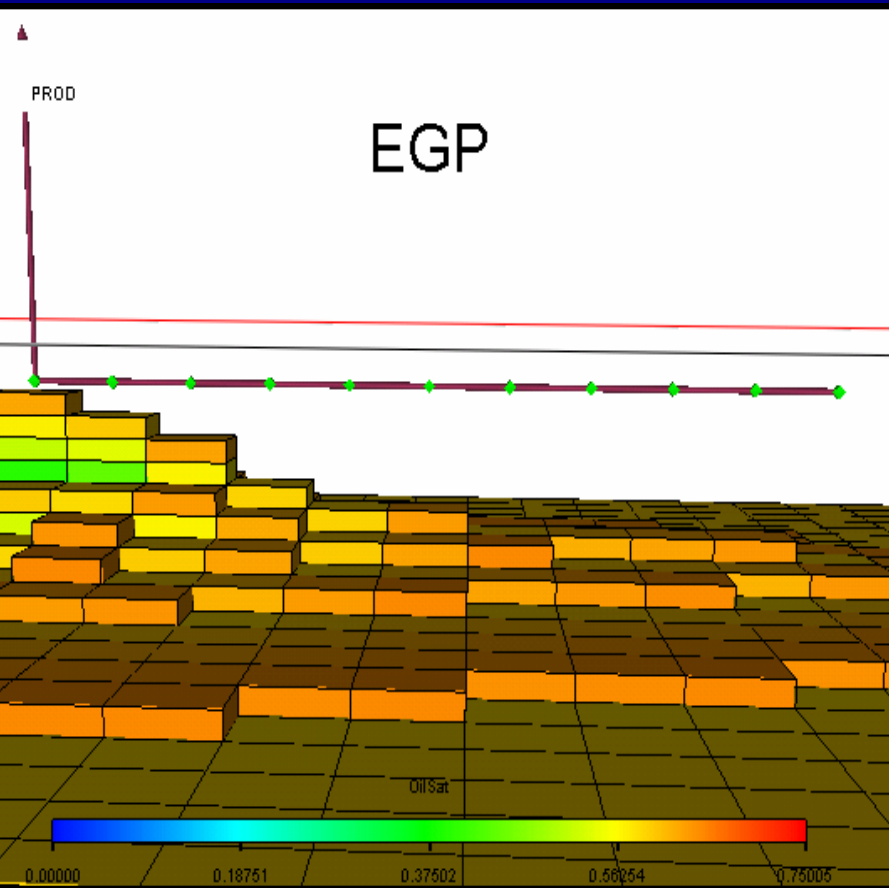

# Slide courtesy of Shell International

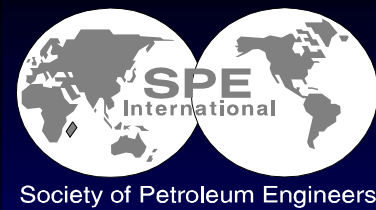

## Productivity improvement of ESS completion compared to alternative completion methods

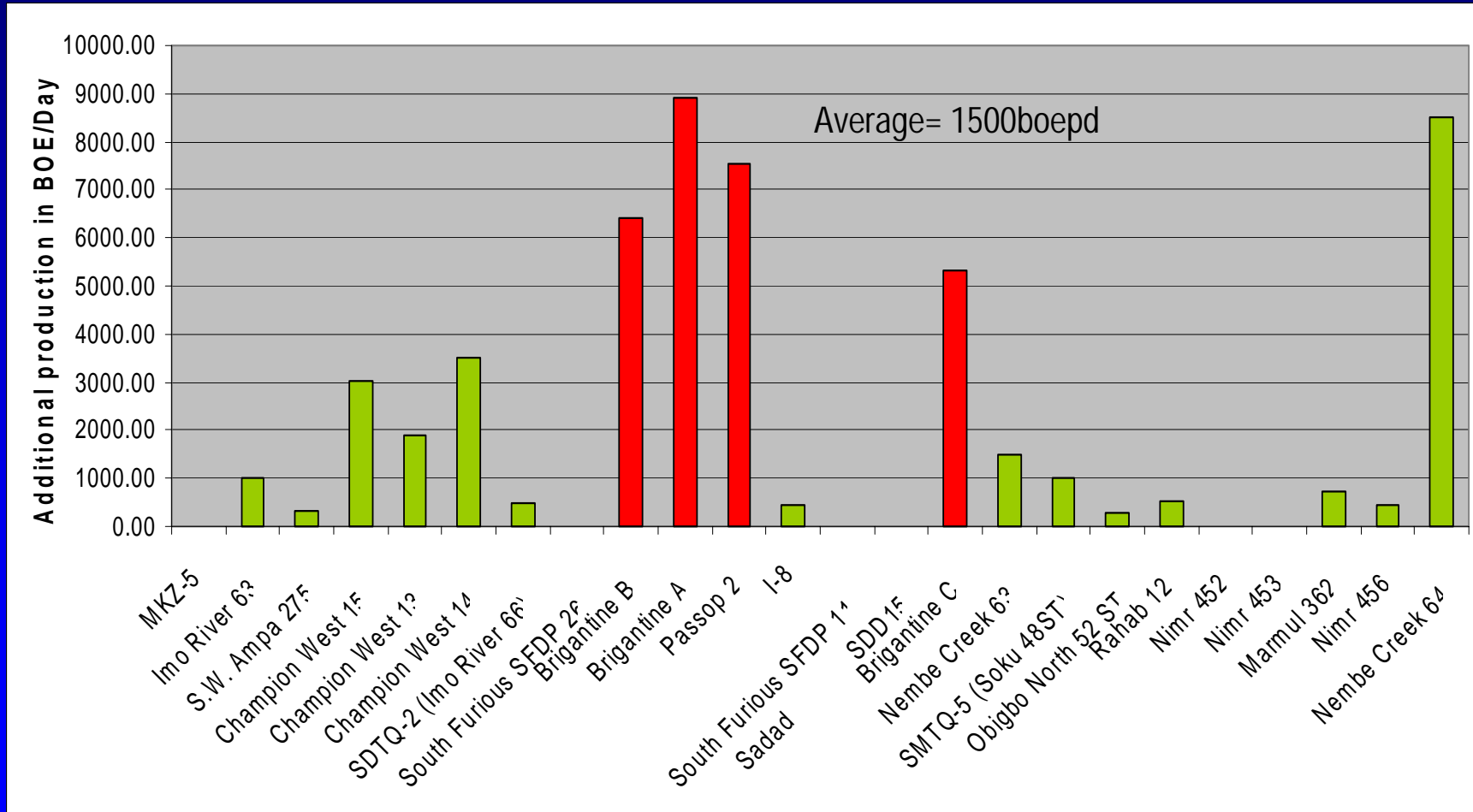

# Expandable Sand Screen Installation Overview

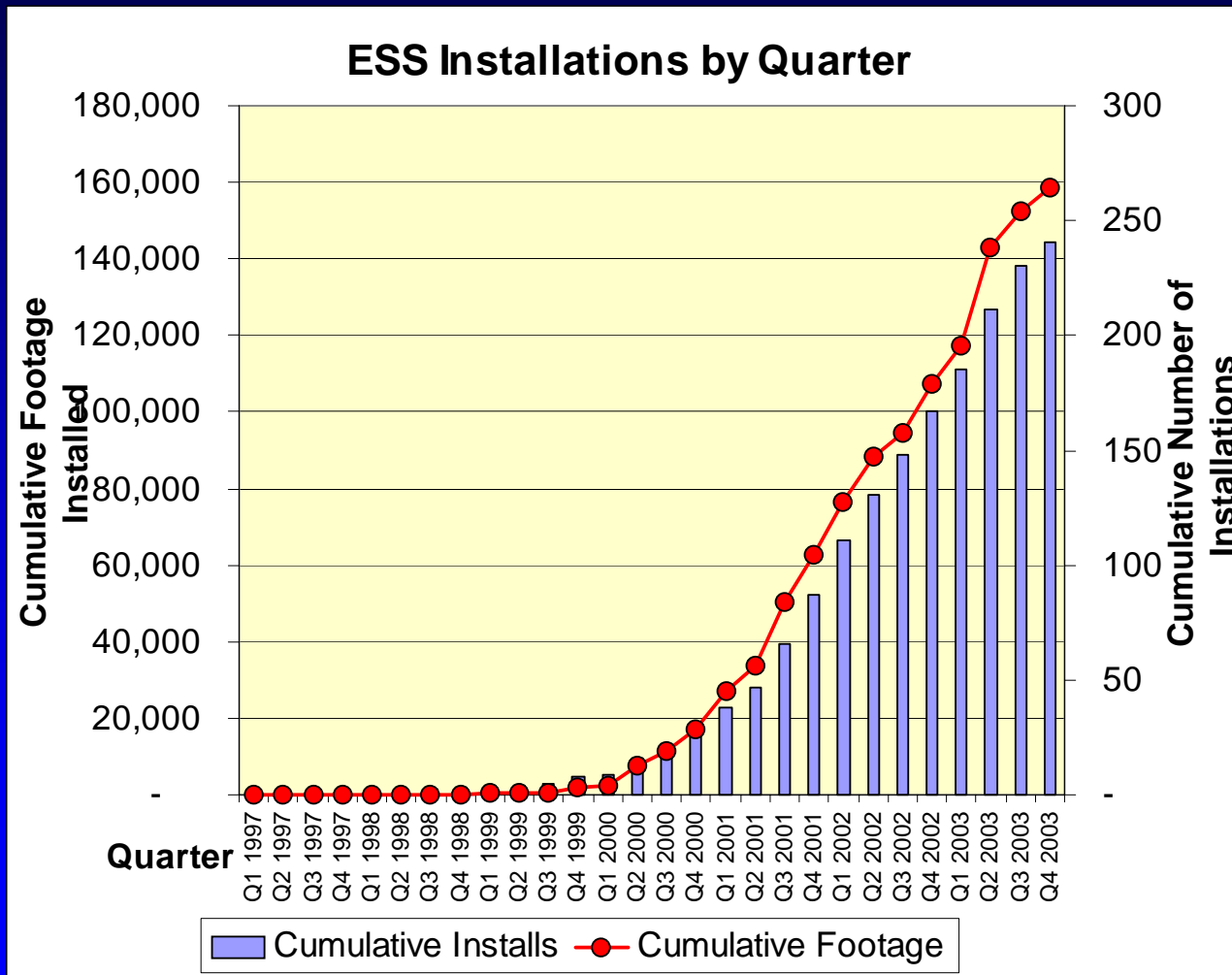

**247 Jobs to End of Q4 2003**

# Expandable Well Technology

## Historical Slotted Expandables Installation Completion Data

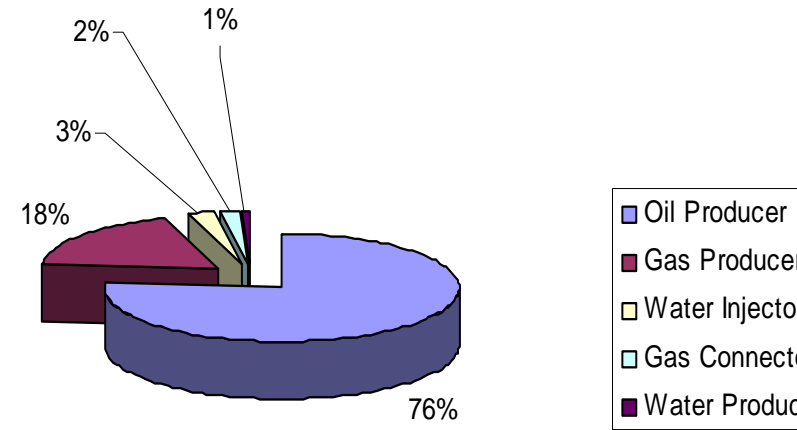
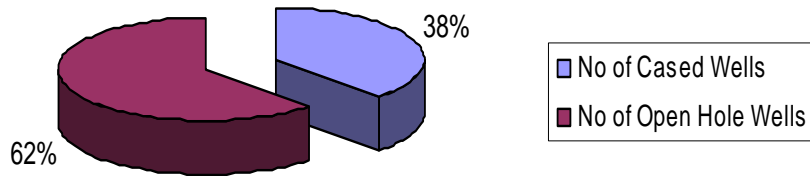

## Expandable Slotted Tubular Applications

# Cased-hole oil well

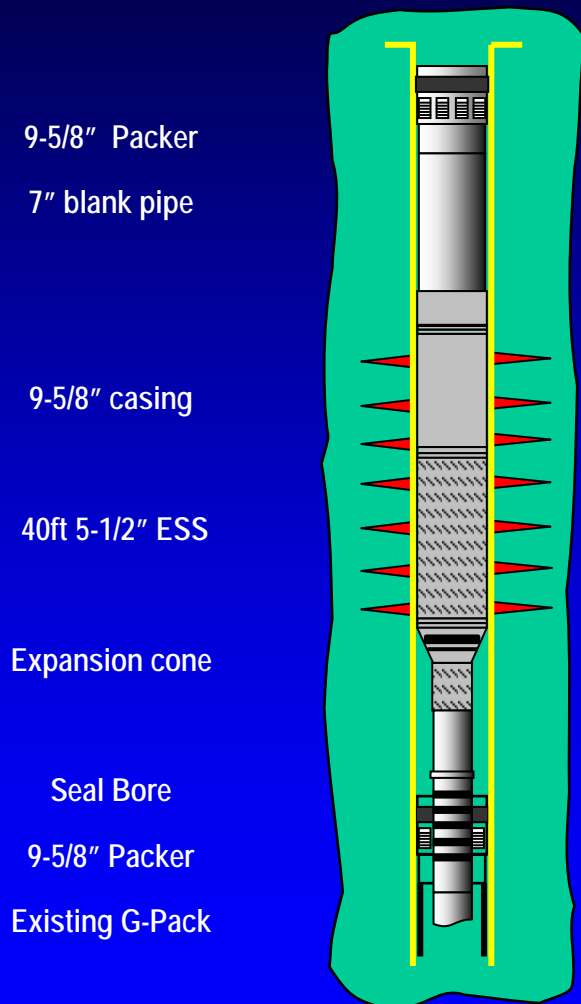

- Vertical @ 2909ft - land based, Jan '98
- Gravel pack too expensive & declines of 50% - No local knowledge
- Well sorted sands in Gharif formation
- 12spf, 45 deg big hole. 230 micron allows initial fines production, perf velocities kept below 0.3 ft/s
- Fixed cone expansion - 50,000lbs
- 1230bbl/d , sand free - as good as GP
- Sustained production rate

**Expandable Slotted Tubular Completions**

# Open-hole gas well

- ◆ 5-7/8" hole at 61 deg, 15,485ft - land based
- ◆ Water-gas contact movement - need for variable shut-off
- ◆ No conventional sand control allows reservoir management
- ◆ 240ft 4" , 270 micron ESS (selected after mud flow-back tests)
- ◆ Difficult hole - shale leading to restrictions, work screens to TD
- ◆ Fixed cone expansion - held up 20ft from TD (in shale)
  - 50 MMscf/d, sand free, -0.8 skin

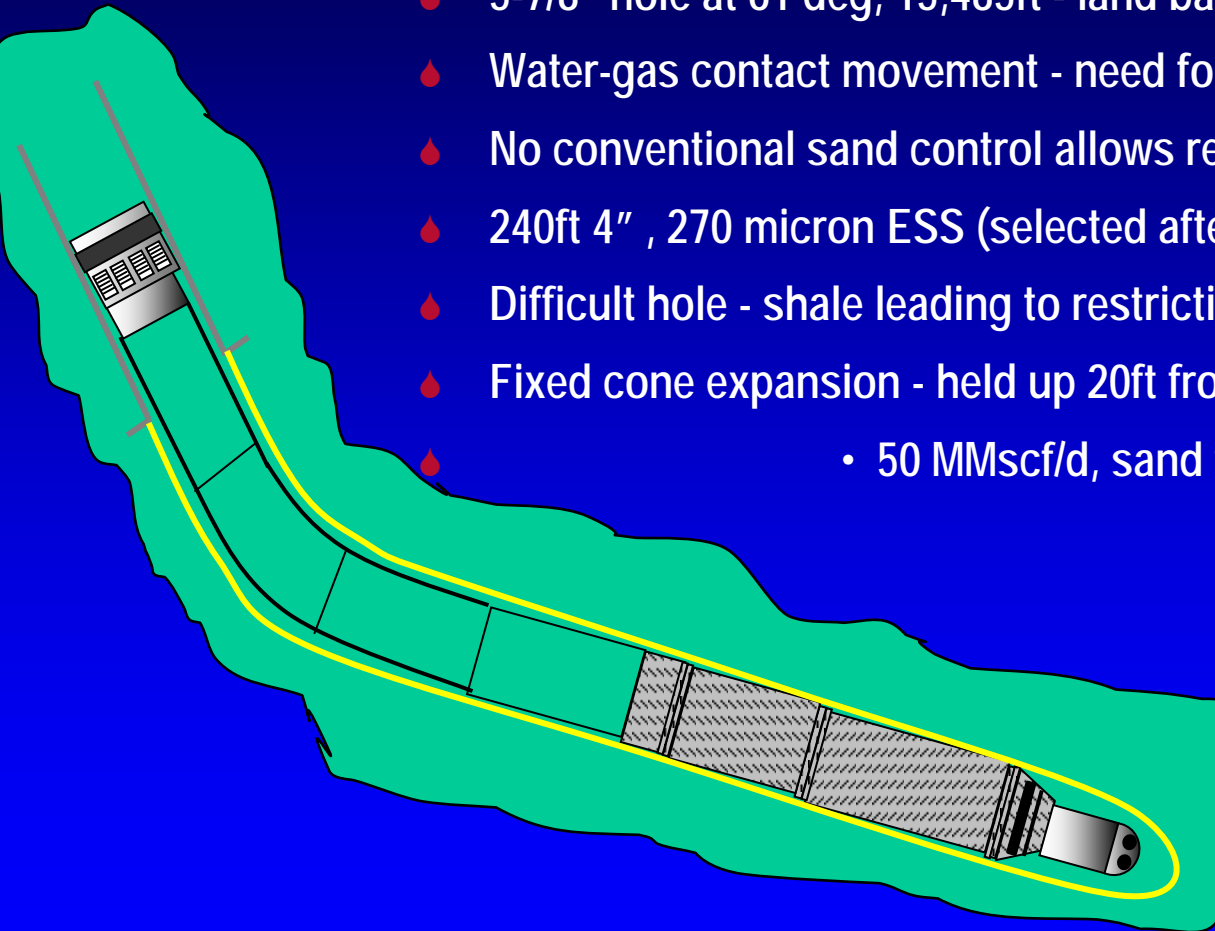

**Expandable Slotted Tubular Completions**

# Horizontal Oil well

- 7" horizontal hole @ 8014 ftah - land based
- Objectives of increasing production with reduced well cost
- ESS increases inflow area whilst allowing slim well design
- 1132ft of 4" , 230 micron ESS
- Fixed cone expansion - 20,000lbs WOB
- 1243 bopd - best PI in field
- Well costs were 23% lower than plan and 30% lower than a conventional well design.

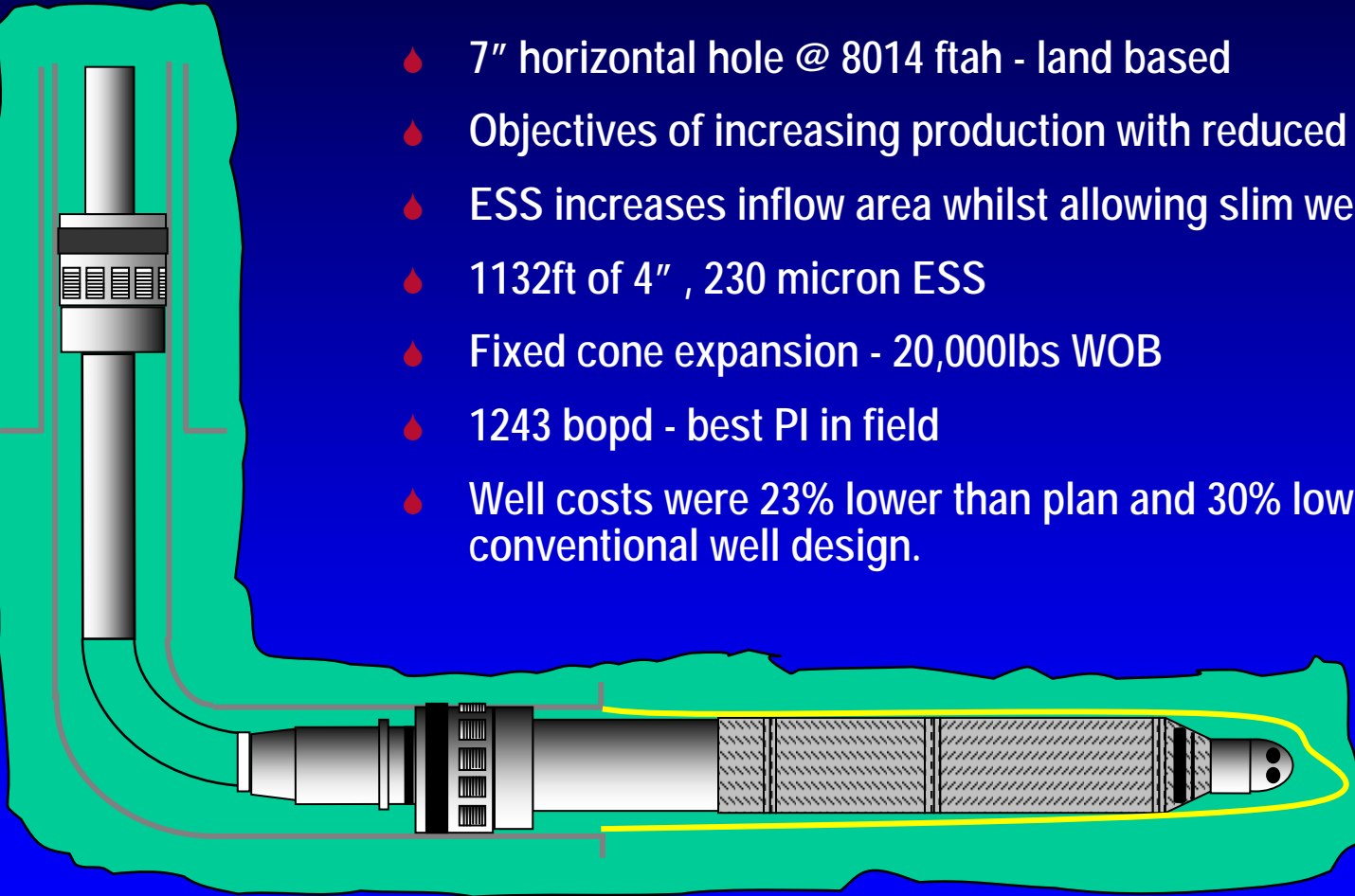

**Expandable Slotted Tubular Completions**

- 3 wells, 6" hole, 4000-7000ft reservoir sections ~ 15,000 ftah
- High gas rates required a large bore, slim well design
- Extremely difficult gravel pack operation - tender assist and good weather required
- ESS<sup>®</sup> allows lower pressure drop, reduced erosion velocities
- Fixed cone expansion + rotary compliant expansion
- 30% more production than anticipated
- Overall the ESS campaign added \$13.5m NPV to project

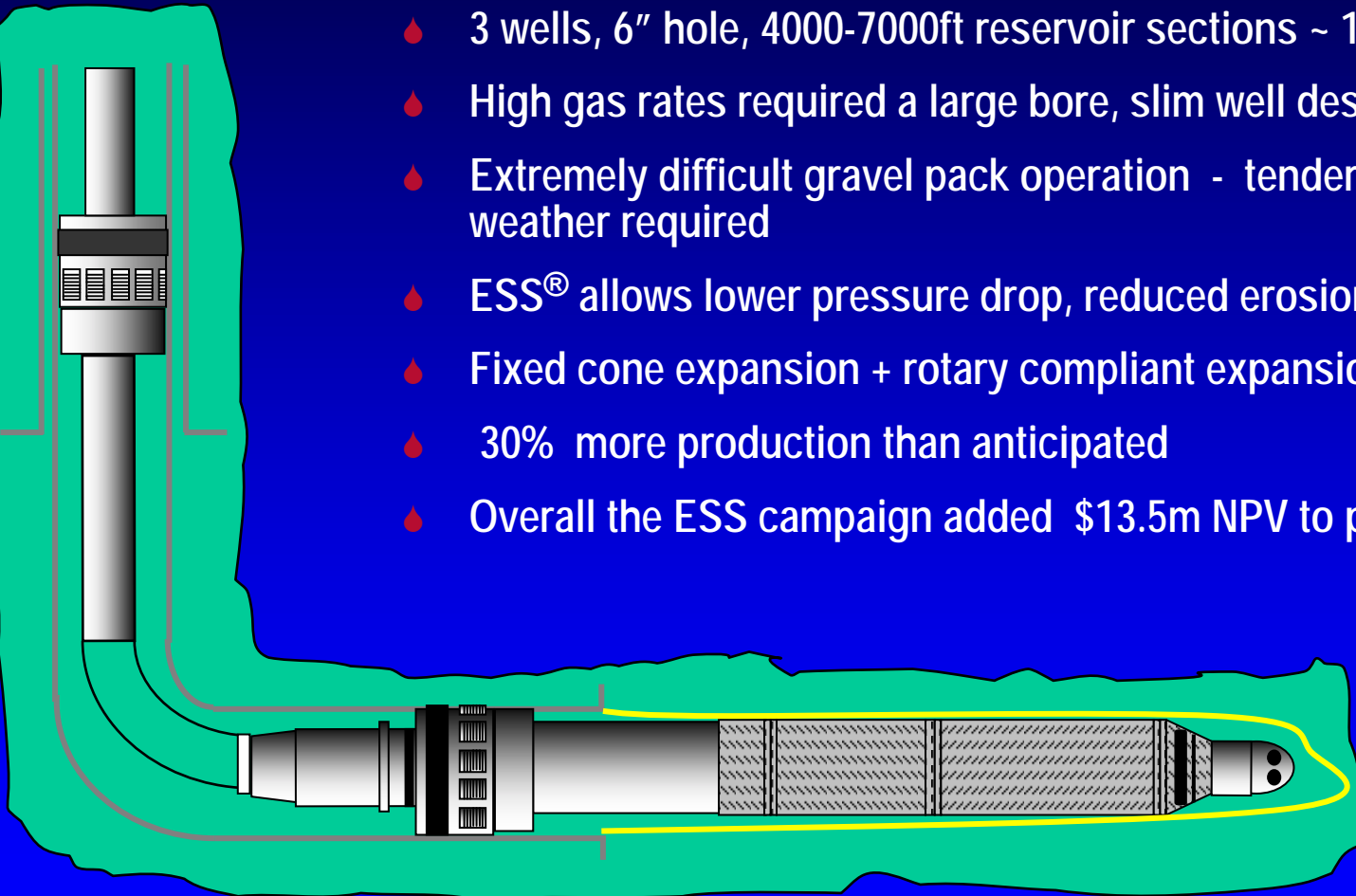

**Expandable Slotted Tubular Completions**

# Expandable Well Technology

---

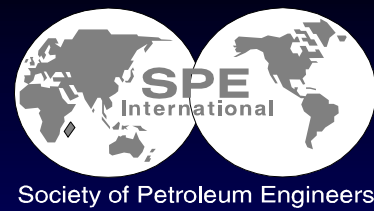

## Solid Expandable Tubulars

---

# Solid Cone Liner Expansion



# Solid Tubular Expansion Rotary Expansion



# Expandable Solid Tubular Drilling Applications

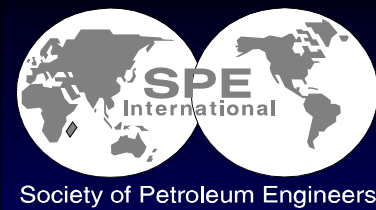

- **Total No of SET Wells**            **228**
  - **Total Footage Installed**        **214,000**
  
  - **Total No of SET Wells YE 2002**   **113**
  - **Total Footage Installed YE 2002** **108,000**
- 102% growth in 1 year

## Casing Remediation

**Casing Cladding**  
**Parted / Split Casing Repair**  
**Subsidence Repair**  
**Perforation Shut-off**

---

**Solid Expandable Application**

# Casing Remediation

Casing Cladding

Corroded / Parted / Split Casing Repair



**STE Casing Clads:**

**Perforation Shut-off** →

← **Corroded Casing Repair**



**Solid Expandable Application**

# Casing Remediation

## Subsidence Repair



Society of Petroleum Engineers

Before Subsidence

After Subsidence

After Removal of Buckled Casing

Subsidence



Casing



Buckled Casing

Damaged Casing Removed

Liner-Hanger Joint With Elastomeric Coating

Removed Casing

5-1/2-in. Casing

Expanded 4-1/4 x 5-1/2-in. Expandable CHL

Solid Expandable Application

# Wellbore Size Preservation

Sidetracking utilizing Solid Expandables



## Enables more efficient Sidetracks:

- Sidetrack deeper (in smaller tubulars)
- Complete well with larger completion

**Solid Expandable Application**

## Wellbore Size Preservation

**Lost Circulation / Shallow Flow  
Premature Casing Shoe Depth  
Discrete Wellbore Support Liners**

## Monobore Liners

---

**Solid Expandable Application**

# Wellbore Size Preservation

Pore Pressure / Frac Gradient Challenges



**Solid Expandable Application**

# Wellbore Size Preservation

## Pore Pressure / Frac Gradient Challenges

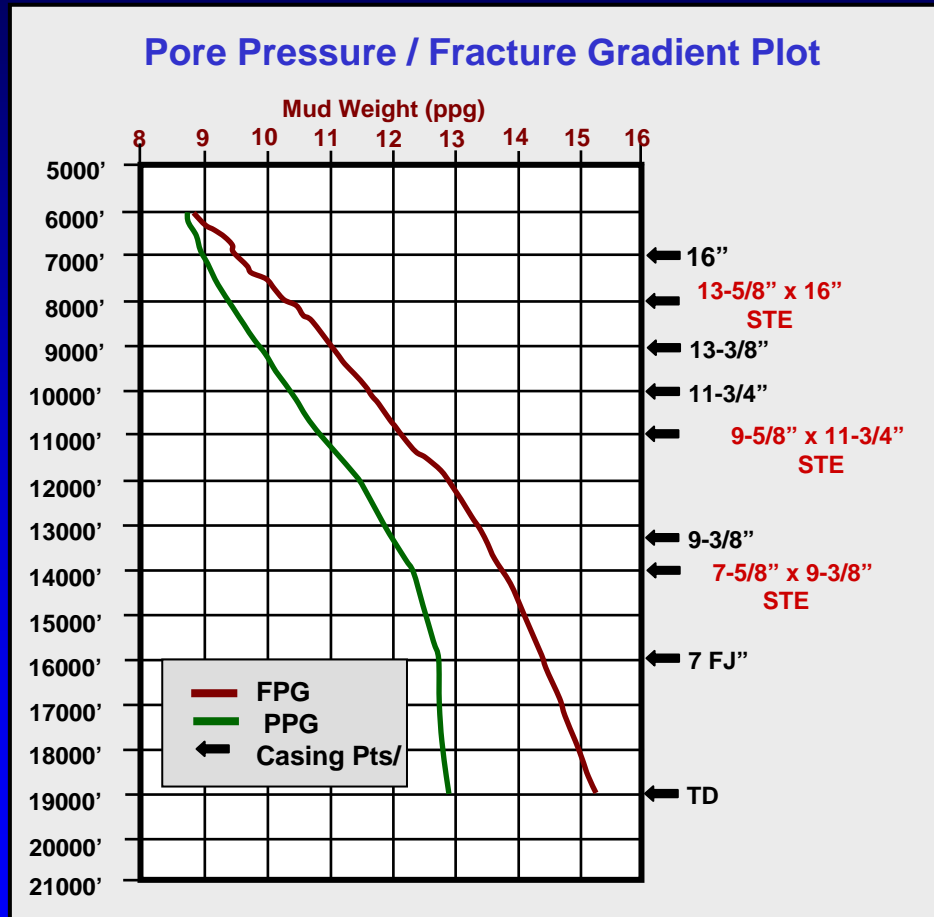

Solid Expandable Application

# Wellbore Size Preservation



Requires 5<sup>th</sup> Generation Rig      Requires 3<sup>rd</sup> Generation Rig

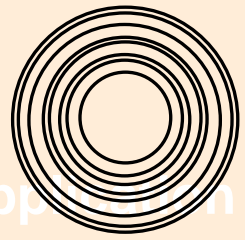
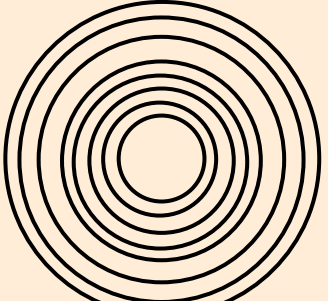
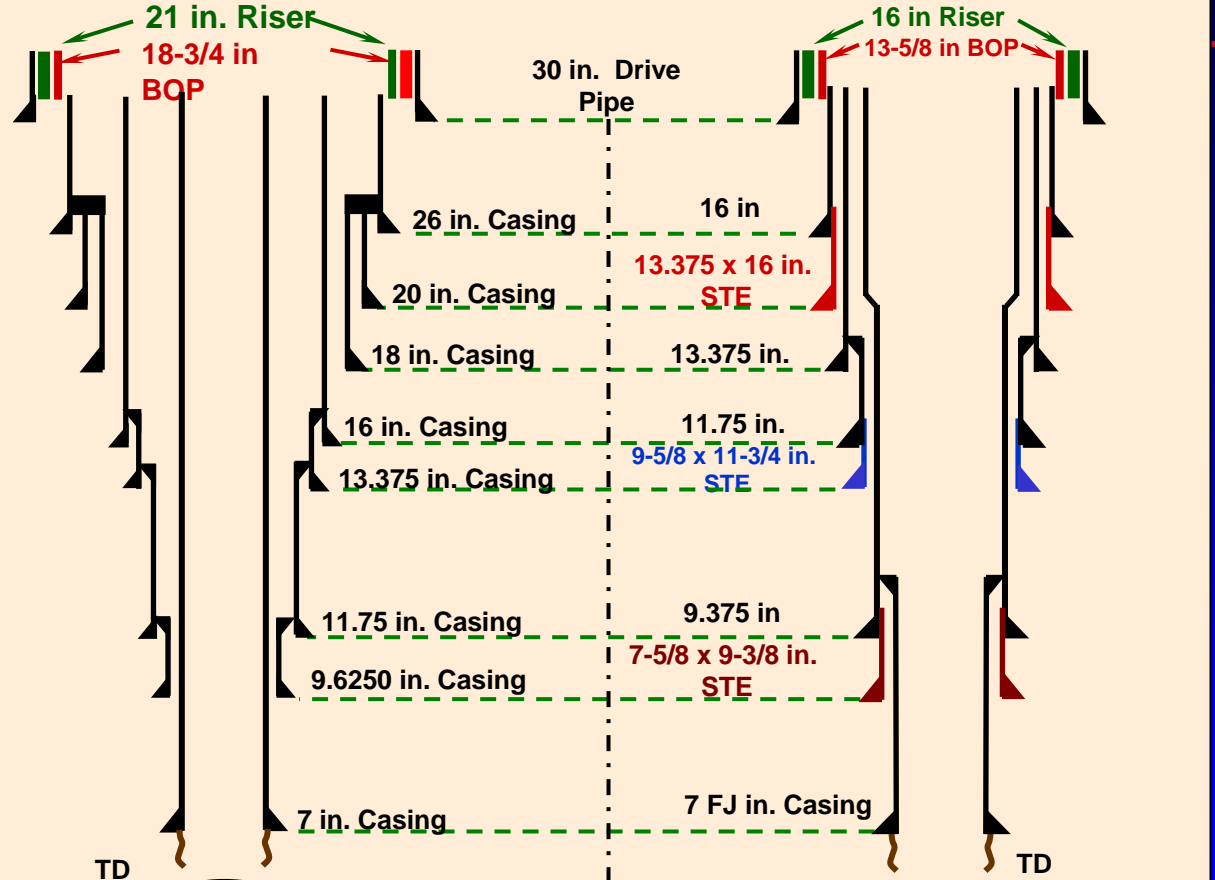

Application

**STE Enables:**

- Pore Pressure / Frac Gradient Solutions
- “Slimming” of Wells

# Expandable Well Design

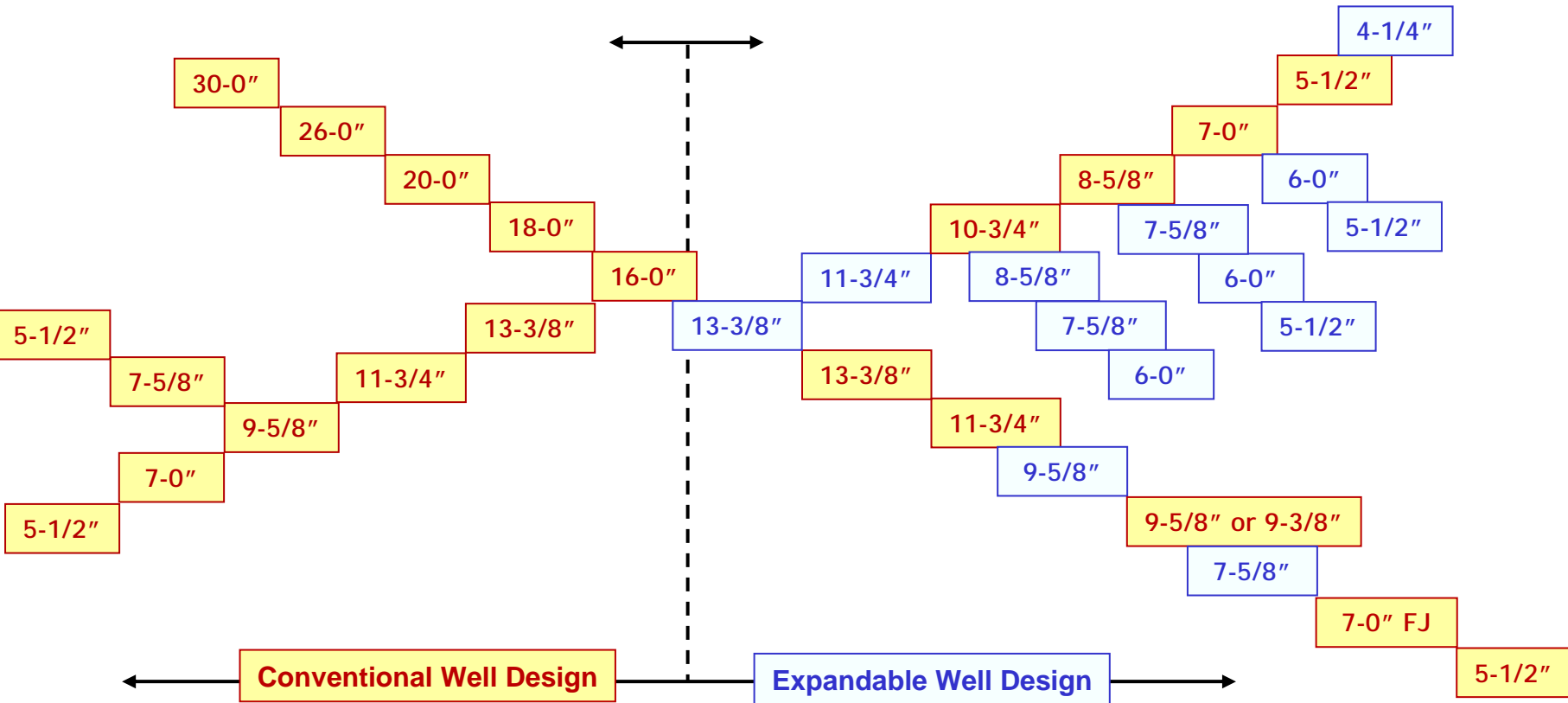

Decision Tree

# Wellbore Size Preservation

## Downsizing Casing Program



Society of Petroleum Engineers

### Downsizing of Field's Casing Program

Increasing Field's ROI

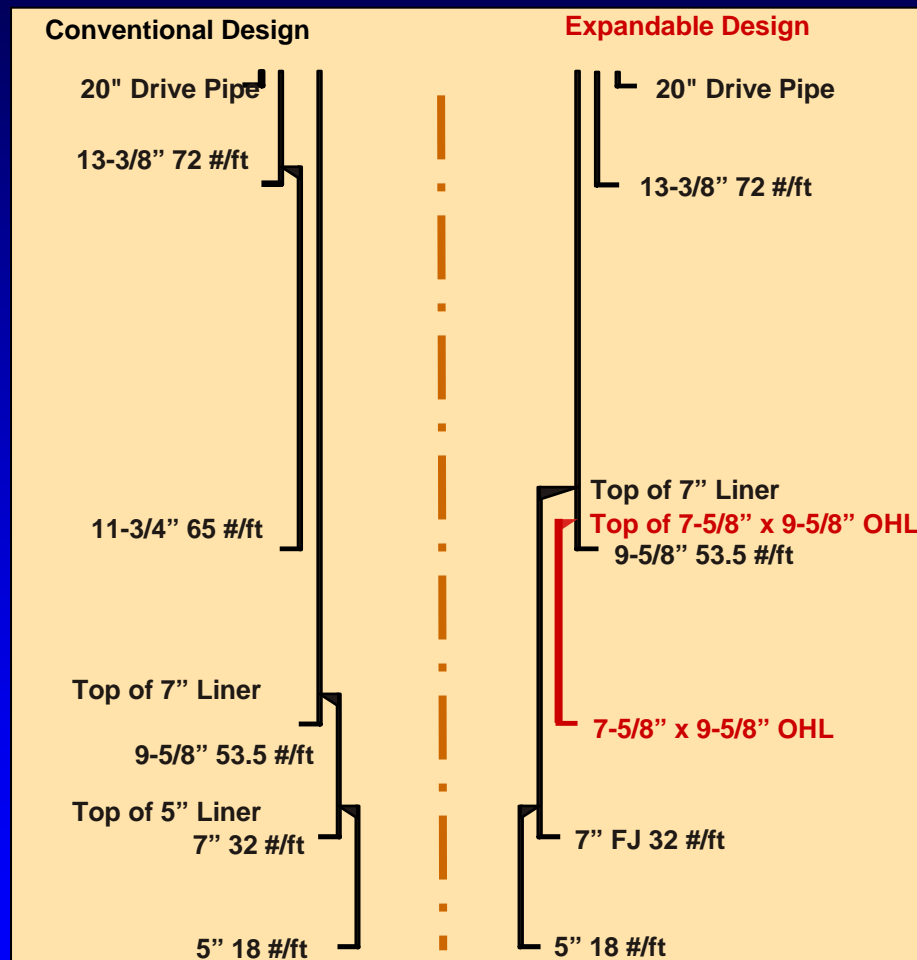

## Solid Expandable Application

# Wellbore Size Preservation Water Shut-off

## Discrete Openhole Application

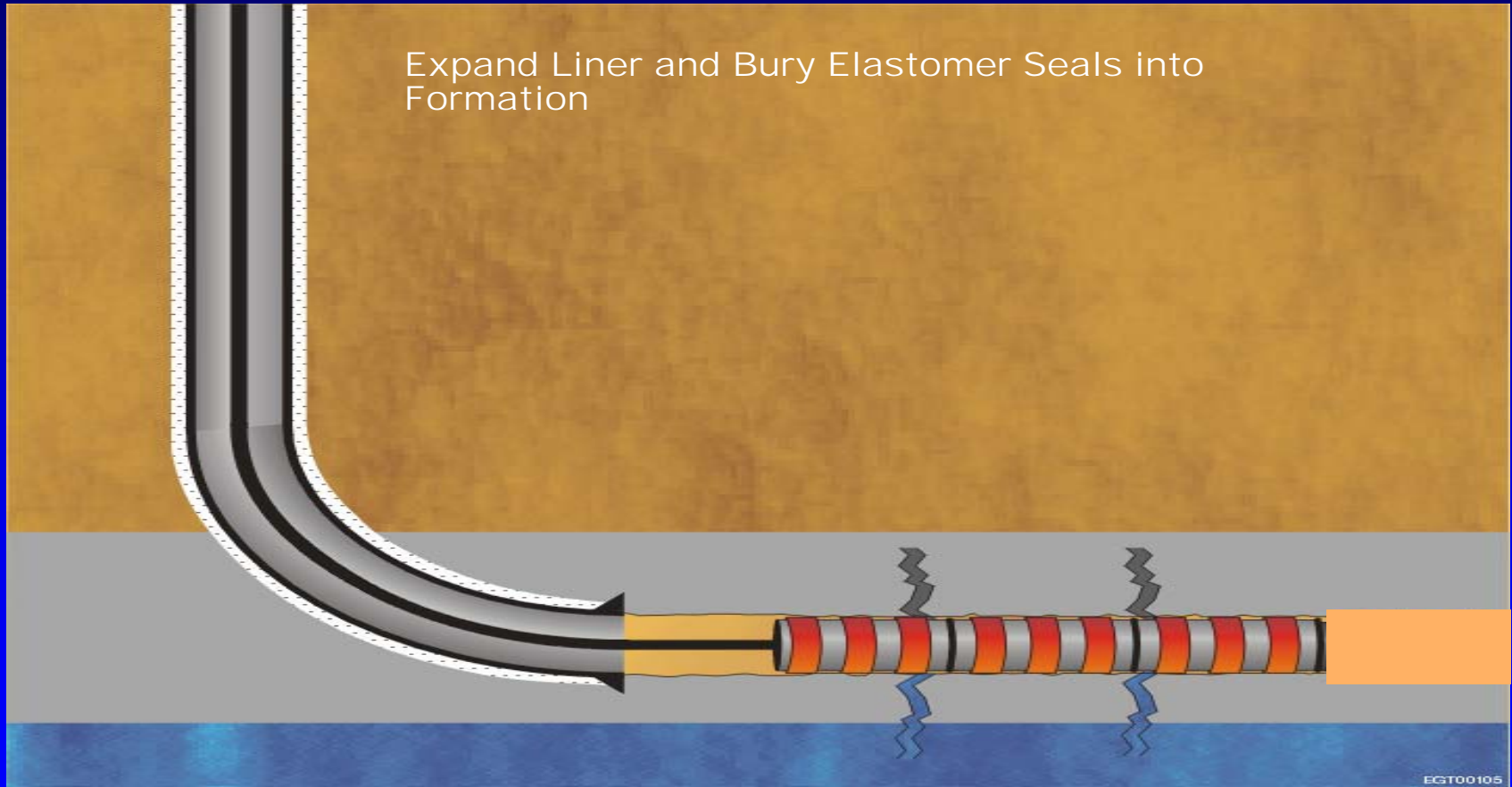

## Solid Expandable Application

# The Future

## Monobore Liners/Wells

---

# Wellbore Size Preservation

## Monobore benefits

Simplified wellhead  
Smaller BOP

Expandable liners  
providing Monobore  
well construction  
capability

Expandable reservoir  
completion system

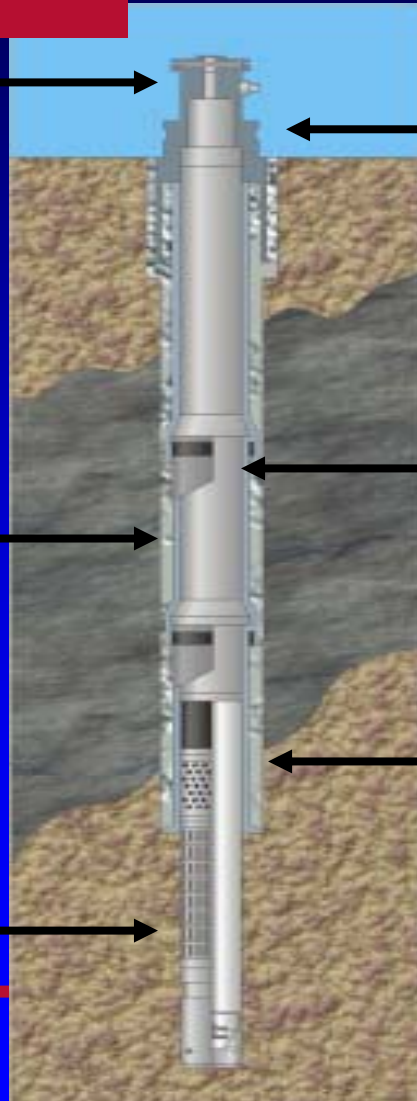

Smaller top-hole sizes.  
Slim-hole drilling  
reduces waste &  
environmental impact

Troublesome hole  
sections are cased  
without sacrificing  
hole size

No packers or liner  
hangers (as we currently  
know them)

**30 - 50% WELL  
COST SAVINGS**

# Wellbore Size Preservation

## Optimised Well Design – Diametric Efficiency

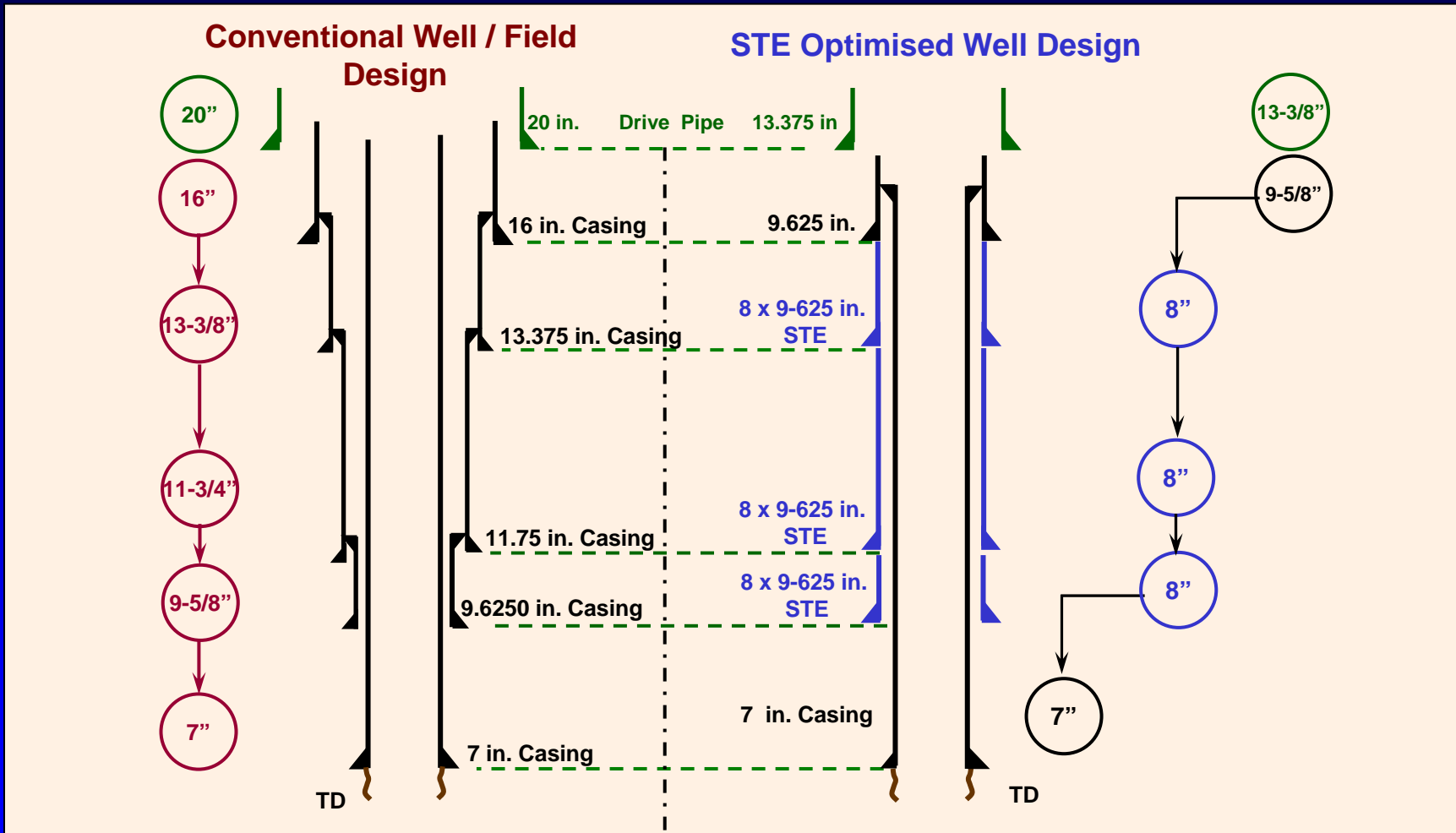

**Solid Expandable Application**

# Expandable Well Technology

---

- **Solid Tubular Expandable Technology**
- **Slotted / Perforated Expandable Tubular Technology**

**It is the way forward to deliver  
tomorrows wells???**

---