



# SPE DISTINGUISHED LECTURER SERIES

is funded principally  
through a grant of the

## SPE FOUNDATION

The Society gratefully acknowledges  
those companies that support the program  
by allowing their professionals  
to participate as Lecturers.

And special thanks to The American Institute of Mining, Metallurgical,  
and Petroleum Engineers (AIME) for their contribution to the program.



*SPE DISTINGUISHED LECTURER SERIES*

# **Low-cost, Non-invasive, Remote Pipeline and Well Inspection Technologies**

*Alberto Di Lullo    Eni E&P Division  
SPE – Italian Section*

## WHAT IS MEANT HERE FOR “INSPECTION”

**Information about the space available to flow**  
(i.e. the pipe from the point of view of the fluid)

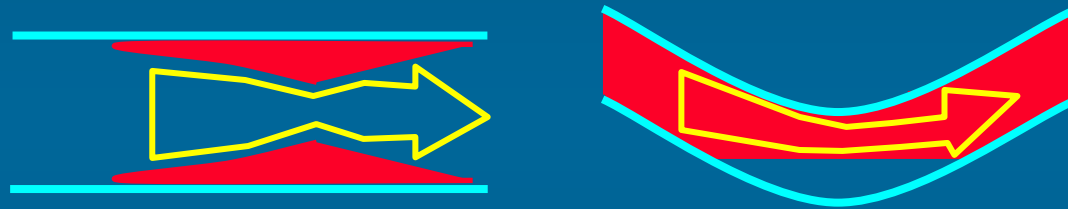

- **Changes in the effective Diameter profile**  
e.g. deposits, valves, wall thickness
- **Presence of interfaces (G/L, L/L)**  
created by stratification of the fluids

# FLOW ASSURANCE DEFINITION

## Flow Assurance

guarantees the achievement  
of the life-time production targets  
of a lifting and transportation system

**by predicting, preventing and solving problems  
directly originated by the behavior of  
the transported substances  
(gases, liquids, solids)**

either as single phases or  
in multiphase conditions

## WHY FLOW ASSURANCE NEEDS MONITORING

### WE NEED FLOW ASSURANCE MONITORING BECAUSE:

- Solutions may reduce the **rate** of problems or may **create new problems**
- **Cost reduction** leads to **progressive optimizations**, which must be validated
- Some problems may affect **Pipeline Integrity** or impede intelligent pigging
- Some problems require **really expensive** interventions, which must be **optimized**

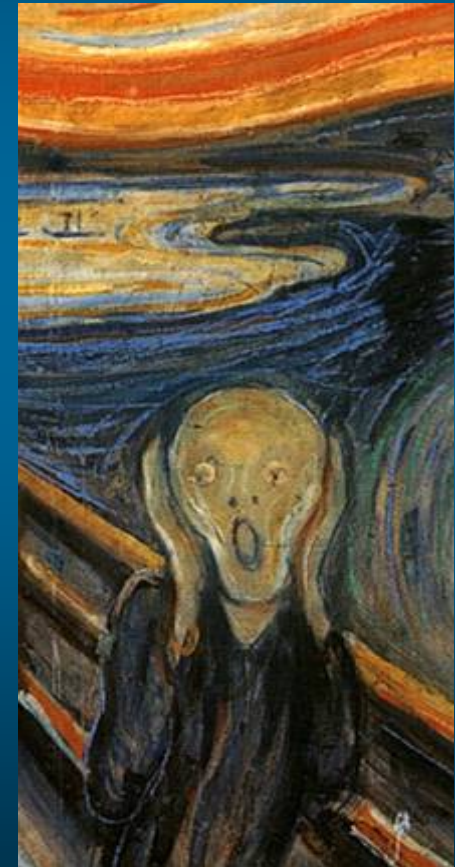

# PRESENTATION AGENDA

## Overview

- Contexts needing pipeline and tubing inspection
- Limitations of Steady–State Monitoring Techniques
- Alternatives to Steady–State Techniques
- Transient based inspection technologies
- Field applications and examples
- Conclusions

# STEADY-STATE MONITORING

## Different states, same measurements

### DISTRIBUTED vs CONCENTRATED RESTRICTIONS

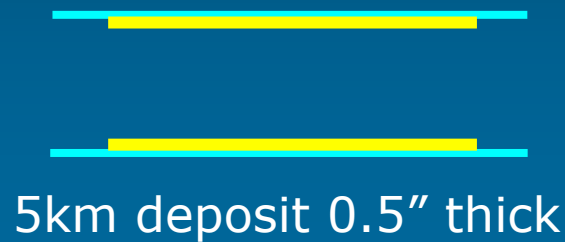

15" ID

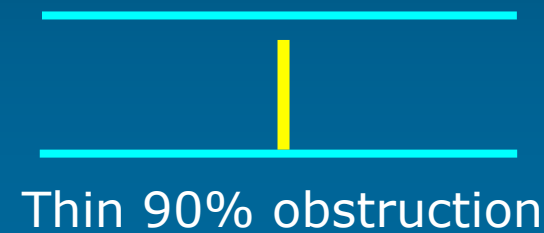

Induce the SAME additional  $\Delta P$

Deposit volume = 73 m<sup>3</sup>

Deposit volume = 0.5 m<sup>3</sup>

**QUANTITY AND POSITION OF DEPOSITS  
CANNOT BE ESTIMATED**

# STEADY-STATE MONITORING

## Different states, same measurements

### SENSITIVITY in DETECTING DEPOSITS



Induce a **SMALL** additional  $\Delta P$  ( $<0.5$  bar)

Equivalent causes:  $\Delta Q < +5\%$     $\Delta\mu < 20\%$     $\Delta\rho\dots$     $\Delta T\dots$

**UNCERTAINTY HIDES THE EFFECT OF SLOWLY GROWING RESTRICTIONS**

**STEADY-STATE MONITORING**  
**Different states, same measurements**

**DEPOSITS WITHOUT  
PHASE-DIAGRAM PREDICTABILITY**

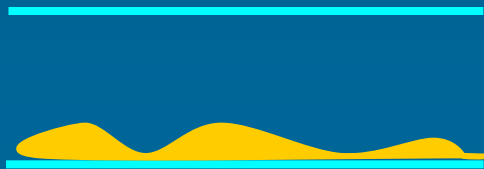

Sand

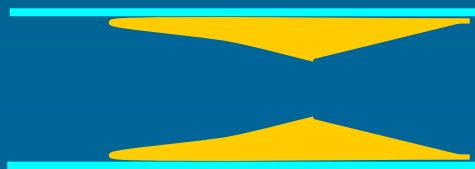

Ineffective chemicals

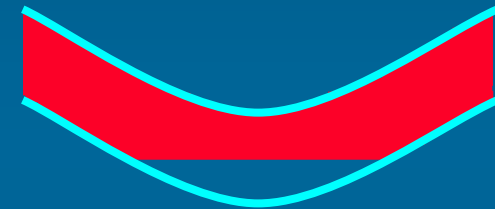

Unexpected bottoms

**THE PRESENCE AND QUANTITY OF  
UNPREDICTABLE DEPOSITS  
MUST BE GENUINELY DETECTED**

# PRESENTATION AGENDA

## Overview

- Contexts needing pipeline and tubing inspection
- Limitations of Steady–State Monitoring Techniques
- **Alternatives to Steady–State Techniques**
- Transient based inspection technologies
- Field applications and examples
- Conclusions

# ALTERNATIVES TO STEADY-STATE TECHNIQUES?

## TWO POSSIBILITIES

- **ANALYSIS OF PASSIVE NOISE**

Noise with no change of production conditions

Potentially applicable for continuous monitoring

- **ANALYSIS OF FLOWRATE TRANSIENTS**

Transients create waves which “explore” the line

Need for temporary changes in production conditions

## ALTERNATIVES TO STEADY-STATE TECHNIQUES?

### PRO'S and CON'S OF THE TWO POSSIBILITIES

- PASSIVE NOISE

**PRO:** Works under normal production

**CON:** Applicable to very short pipelines (<200m?)

- FLOWRATE TRANSIENTS

**PRO:** Applicable to long wells and pipelines

**CON:** Temporary change of flow conditions



**Passive noise not discussed here,  
but might deserve more exploration**

# PRESENTATION AGENDA

## Overview

- Contexts needing pipeline and tubing inspection
- Limitations of Steady–State Monitoring Techniques
- Alternatives to Steady–State Techniques
- **Transient based inspection technologies**
- Field applications and examples
- Conclusions

# TRANSIENT-BASED INSPECTION CONCEPT

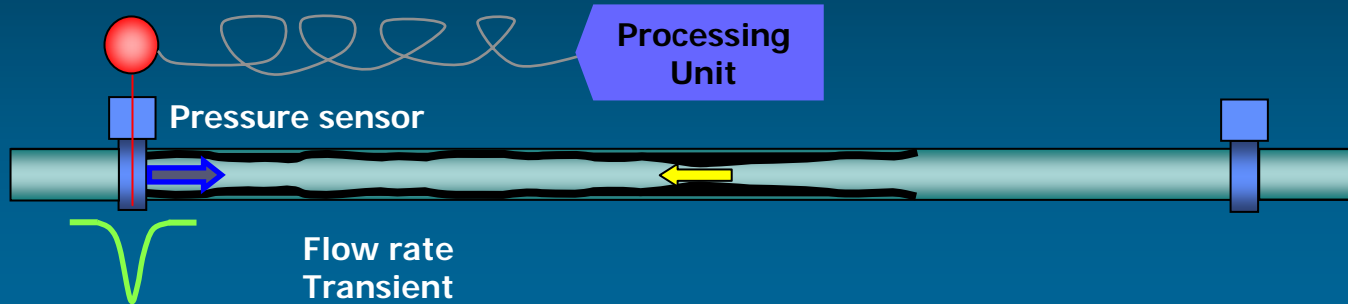

## INSPECTION ACCOMPLISHED BY:

- 1) GENERATING A FAST FLOW RATE TRANSIENT
- 2) MEASURING THE RESULTING PRESSURE EVOLUTION
- 3) ANALYZING THE DATA

**MEASURING PRESSURE IN ONE POINT  
AND NOT MEASURING FLOWRATE**

# TRANSIENT: EXAMPLE OF A REAL MEASUREMENT

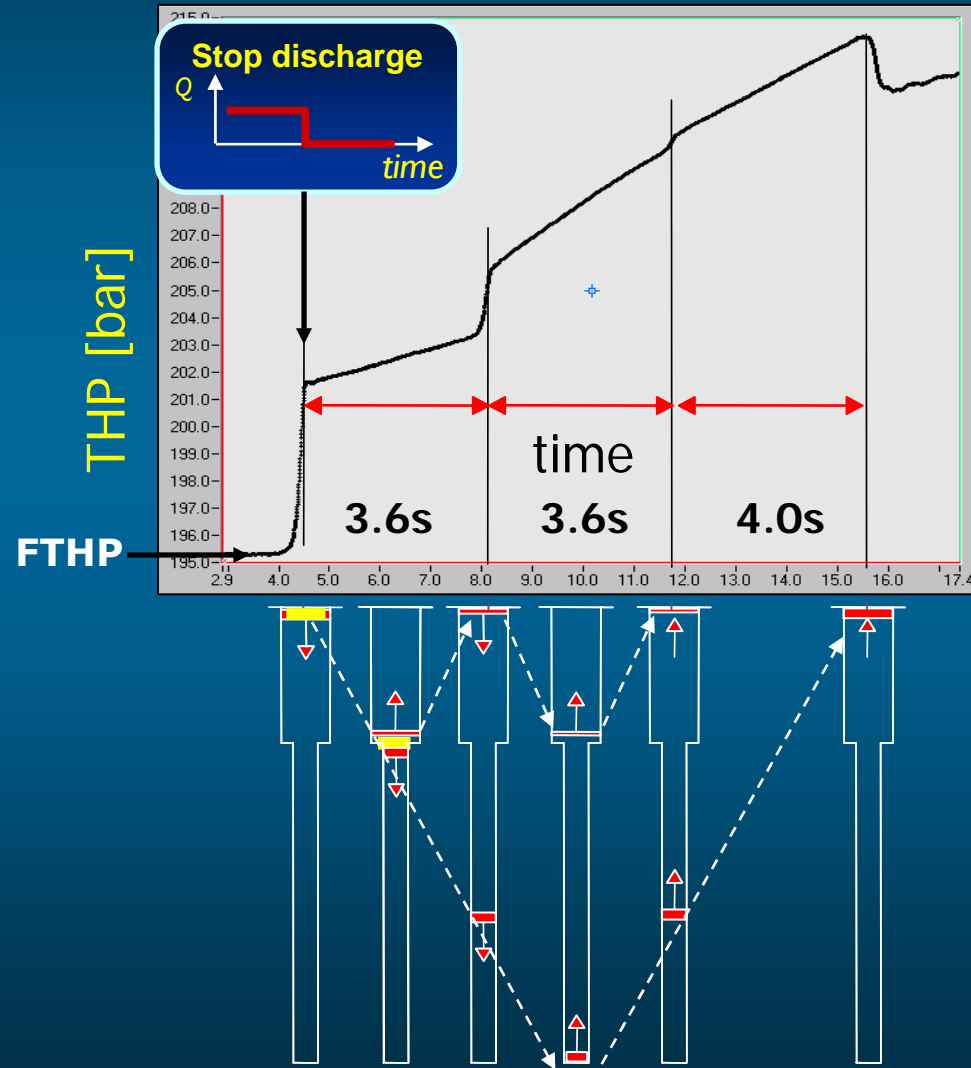
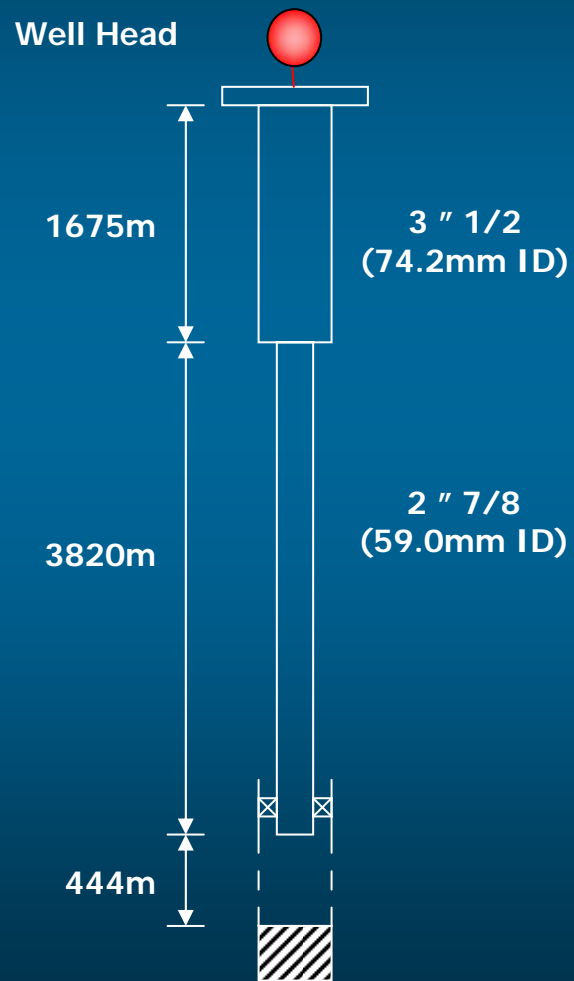

# EXPLOITATION OF FLOW RATE TRANSIENTS

## Theory

Correct modeling  
Simulation software

## Pressure sensors

Accurate at high P  
Fast response

## EXPLOITING TRANSIENTS

## Inverse problem

From P data to profile  
of variables along pipe

## Data acquisition

In the field with operators  
Portable and reliable tools

**PATENTED**

## TRANSIENT-BASED MEASUREMENTS EXECUTION

### TRANSIENTS EXPLOITATION REQUIRES STRONG INTERACTION WITH PLANT OPERATORS:

- Transients must be produced by somebody's **hands**: he/she has to learn how

**Can you learn Tango by exchanging e-mails ?**

- There is no "standard plant"  
Application **flexibility** is mandatory  
Operator's **understanding** is mandatory

# TRANSIENT-BASED, REMOTE INSPECTION TECHNOLOGY

## TBI

**T**ransient

**B**ased

**I**nspection

*(In Eni, we call it PRIMEFLO)*

# PRESENTATION AGENDA

## Overview

- Contexts needing pipeline and tubing inspection
- Limitations of Steady–State Monitoring Techniques
- Alternatives to Steady–State Techniques
- Transient based inspection technologies
- **Field applications and examples**
- Conclusions

# USEFUL TRANSIENTS TYPES AND METHODS

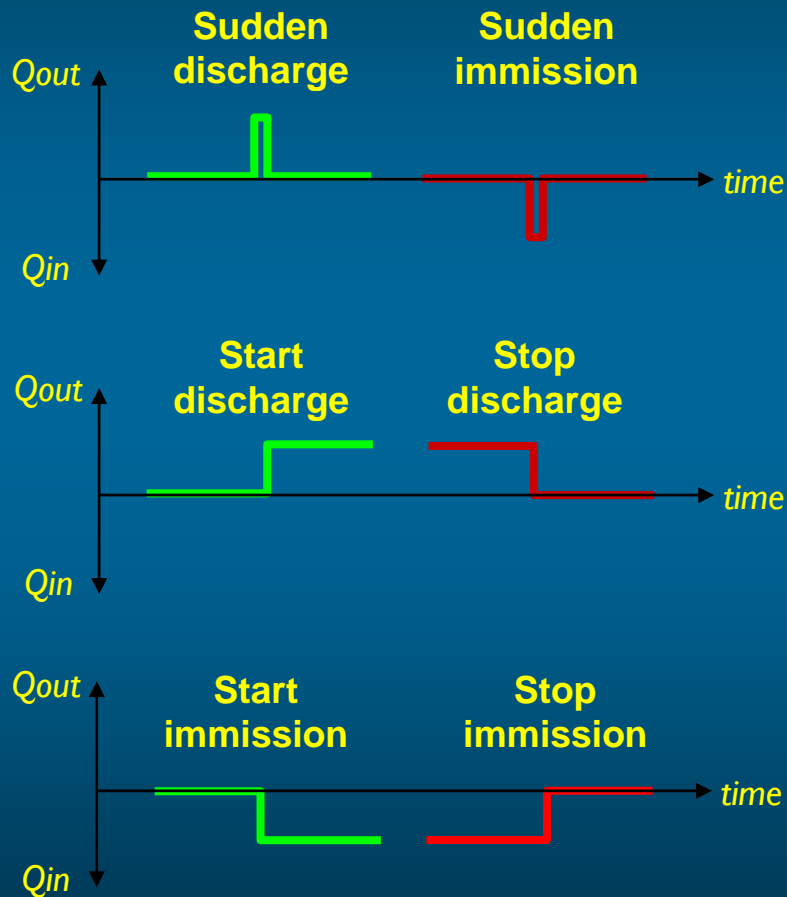

**ANY TRANSIENT  
WILL PROVIDE  
USEFUL INFORMATION  
(BUT NOT IDENTICAL  
INFORMATION !)  
AS LONG AS IT IS  
FAST AND SHARP**

# TBI DEMONSTRATED PERFORMANCE

## FIELD DEMONSTRATED APPLICABILITY

<b>Pipes</b>	Tubing, Pipeline, Sealine
<b>Geometry</b>	Any (H, V, sloped, winded...)
<b>Diameter</b>	1/6" – 32" ↑
<b>Fluid Type</b>	Oil, Gas, Emulsions ( <b>no flowing G+L !</b> )
<b>Viscosity</b>	from gas to 600 cP ↑
<b>Length</b>	<b>Oil</b> 200 m – 530 km ↑
	<b>Gas</b> 3 m – 530km ↑

# TRANSIENTS DISPERSION EXAMPLE OF OIL PIPELINE (530km)

Signal dispersion (width):  
negligible broadening after a 1060km trip  
Equally true for OIL and GAS pipelines

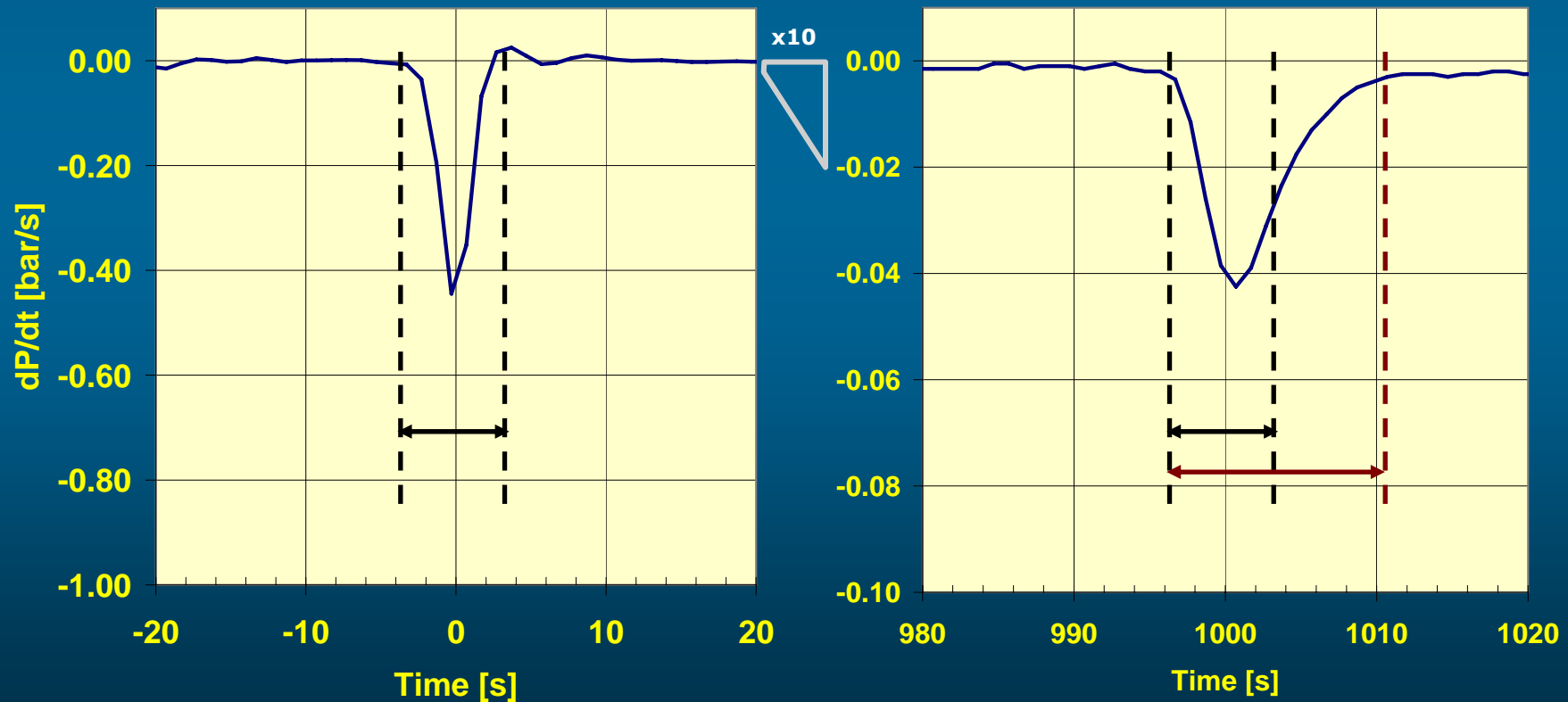

# TBI SENSITIVITY

## DEMONSTRATED SENSITIVITY

Light crude with  $\mu = 2 \text{ cP}$

**350'000 m** far from sensor, **1/4"** / 24" diameter change

Heavy crude with  $\mu = 600 \text{ cP}$

**300 m** far from sensor, **1/8"** / 16" diameter change

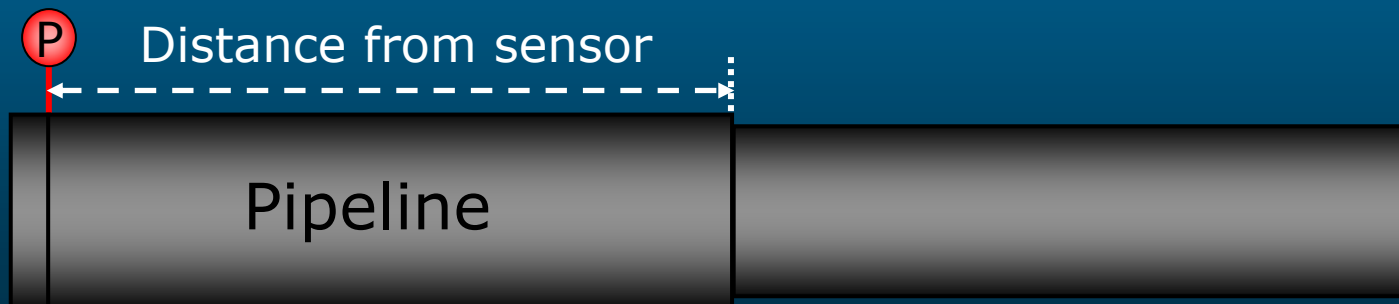

# TBI LIMITATIONS

## CASES WITH LIMITED APPLICABILITY

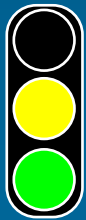

- **Gas lines:**

- ✓ Need to shut-in long lines on both sides
- ✓ Can only localize sharp restrictions, obstructions and interfaces



- **Multiphase lines and wells:**

- ✓ Never applicable in presence of flow
- ✓ After shut-in:
  - ✓ in wells: wait for fluids stratification
  - ✓ in lines: pressurize with liquid
- ✓ Limited to localize (almost) complete obstructions

# TBI LIMITATIONS

## CASES WITH LIMITED APPLICABILITY

- **Leaks:**

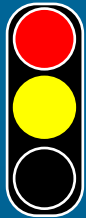

- ✓ No definitive conclusions
- ✓ Probably applicable only with:
  - ✓ very low  $\Delta P$  between inside and outside, to avoid critical flow across the leak (hydrostatics may prevent this)
  - ✓ rather big holes, e.g. like a coin  
→ **THEFT**

## LOW-COST, LOW-RISK, REMOTE AND FAST

### TBI ATTRIBUTES:

- **Remote:** only access to the ends of the pipe is necessary → no “walking” along the line
- **Fast:** measurements does not require long flow stabilization and production is affected for about 5s/km (oil lines) and 15s/km (gas)
- **Low risk:** nothing is introduced in the line, no excavations, no installation, etc.
- **Low cost:** see above + low cost instrumentation

# TBI APPLICATION OIL WELL INSPECTION

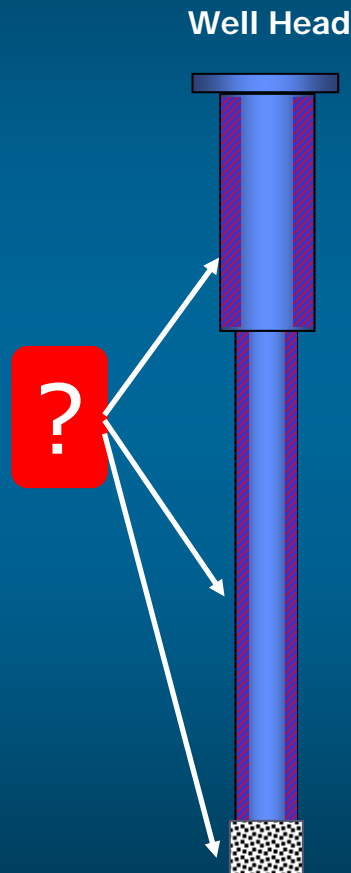

**Oil well losing productivity**

**Deposits of unknown nature,  
localization (tubing/reservoir)  
and distribution**

**Plan best remedial technique  
and verify its effectiveness**

# TBI APPLICATION OIL WELL INSPECTION

Well Head

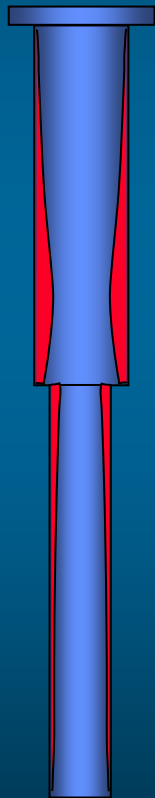

**Before  
acid job**

**TBI  
measure**

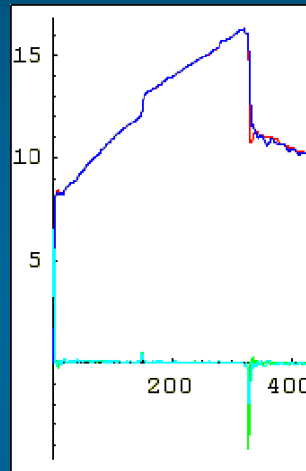

**Internal  
diameter profile**

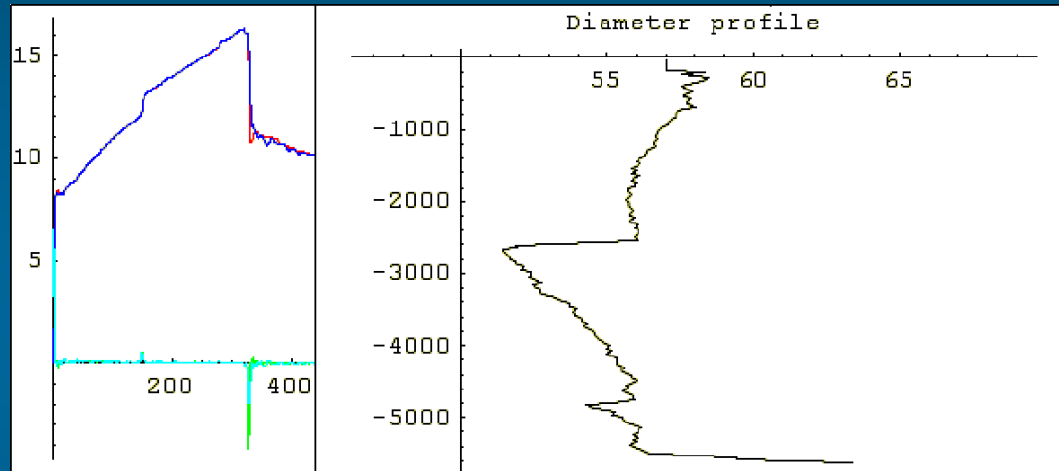

# TBI APPLICATION OIL WELL INSPECTION

Deposits actually removed by the acid job

Well Head

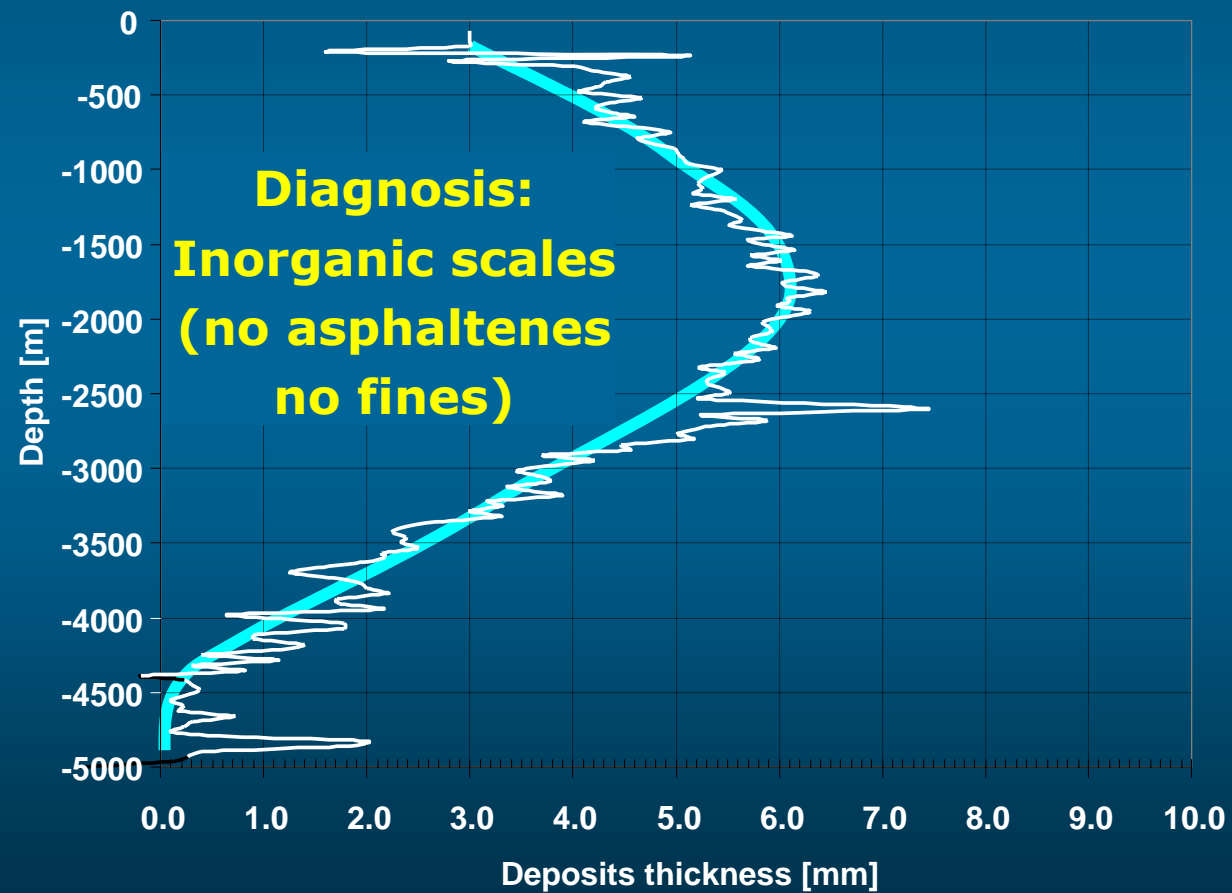
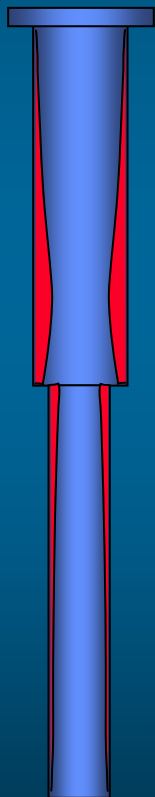

# TBI APPLICATION OIL WELL INSPECTION

Well Head

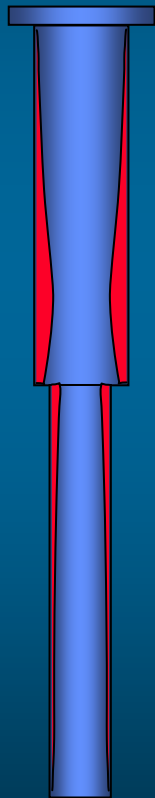

**Before  
acid job**

**After  
acid job**

**TBI  
measure**

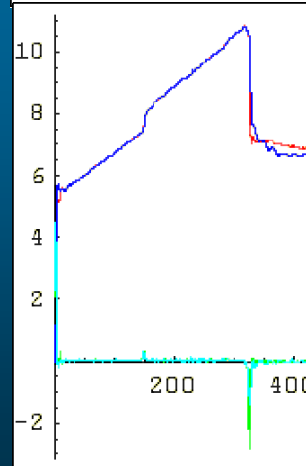
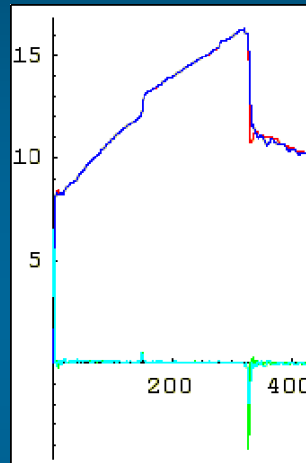

**Internal  
diameter profile**

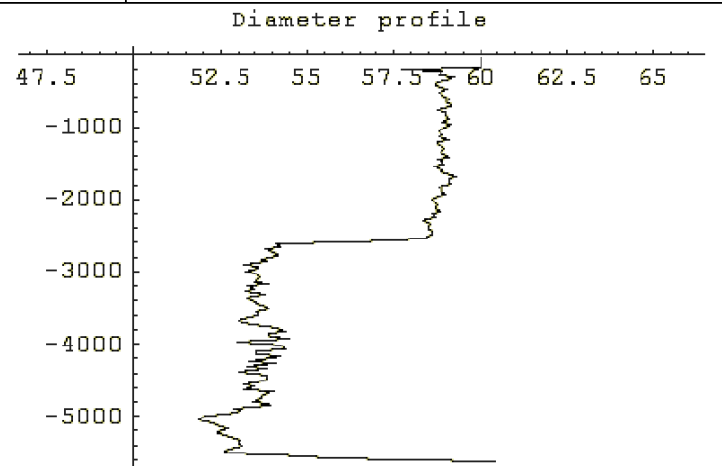
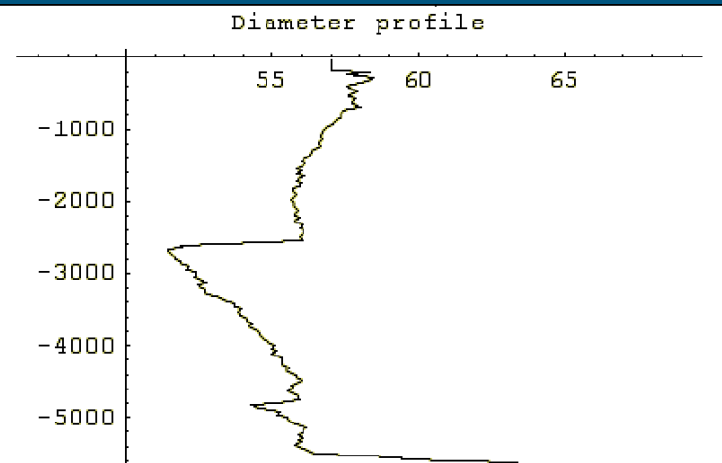

# TBI APPLICATION TO AN OIL SEALINE

Production  
platform

## LOCATE STUCK PIG (OBSTRUCTING)

Onshore  
terminal

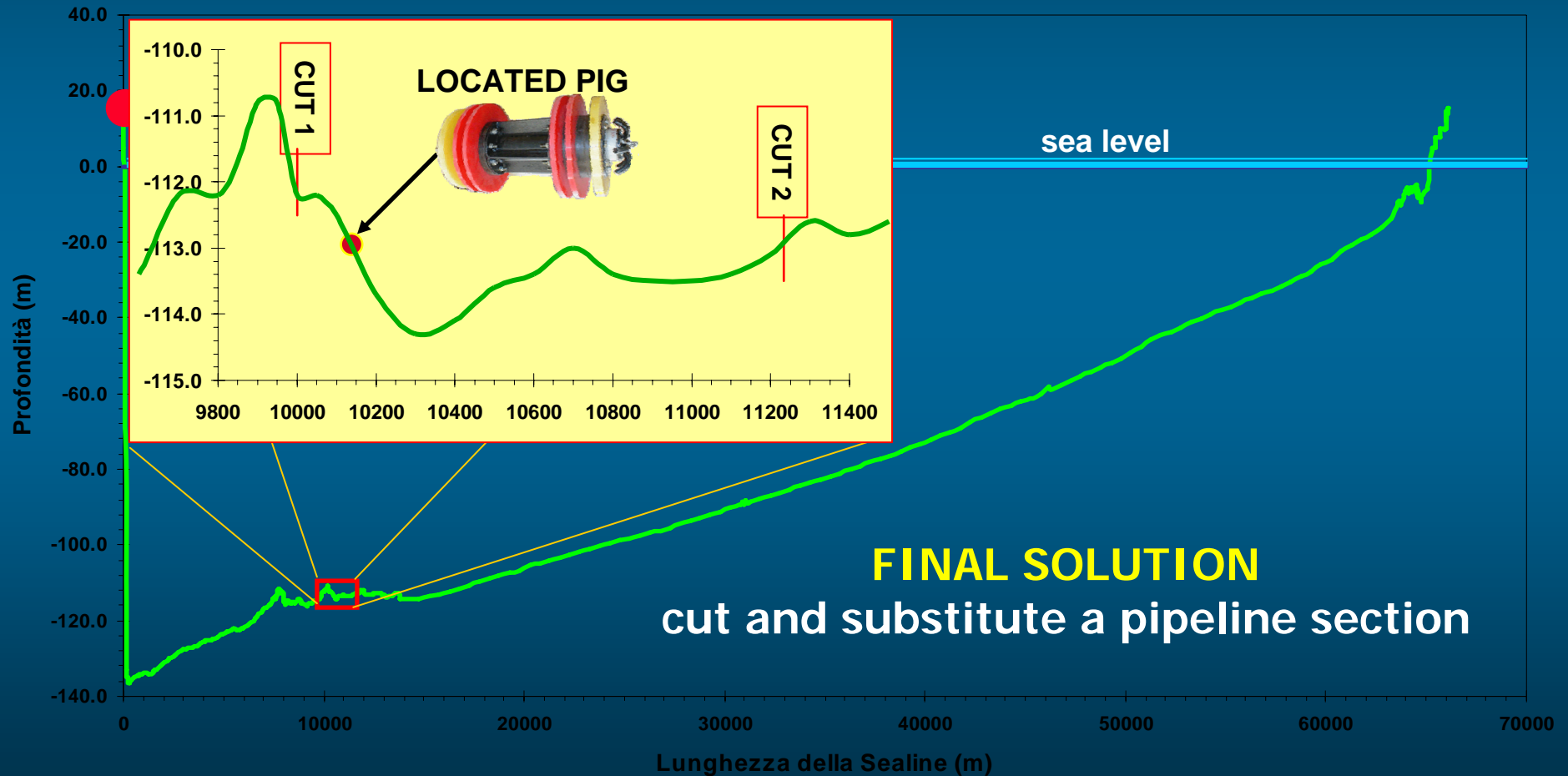

# PRESENTATION AGENDA

## Overview

- Contexts needing pipeline and tubing inspection
- Limitations of Steady–State Monitoring Techniques
- Alternatives to Steady–State Techniques
- Transient based inspection technologies
- Field applications and examples
- **Conclusions**

## **ECONOMIC CONCLUSIONS**

Since its first Eni field application (Dec 2000), TBI impact has been evaluated.

→ **Several million US\$ savings on OPEX**

(reduction of repair and intervention costs,  
optimization of well cleaning jobs,  
reduction of time-to-action)

→ **Several thousands bbl of oil production  
NOT delayed or lost**

## TECHNICAL CONCLUSIONS

OVERALL TECHNICAL MESSAGE FROM TBI:  
Often very easy to gain precious information from  
annoying shutdowns or flowrate changes

→ GENERATE "CULTURAL" ACCEPTANCE OF  
TRANSIENTS AS MONITORING TOOLS:

Never apply transients without asking which  
information they could provide

Stop just "tuning simulations" and  
start to "measure through simulations"

*Thank you for your attention*